



WE WEIGH THE WORLD

CAS COMPANY INTRODUCTION 2026

CAS is celebrating its 43rd anniversary, after starting in 1983, by aiming towards automated robot systems. CAS will keep growing to become the world's best weighing and measuring sensor company that leads the global standard based in its 43 years of experience.

CAS

CONTENTS



CAS Headquarters

01 COMPANY INTRODUCTION

CEO Message	04
Overview	05
Management Philosophy	06
History & Achievements	07
Organization	08
R&D	09
Production Facilities	10
Global Network	11
Domestic Network	12
Service	13
Happy CAS Day	14
Certification	15

02 OUR BUSINESS

Sensor Solution	17
Industrial Weighing Solution	18
Laboratory Weighing Solution	19
Retail Weighing Solution	20
Measuring Instrument Solution	21
Health & Living Solution	22
Calibration Solution	23
CAS Mall	24
CAS CHEMICAL	25

03 SYSTEM APPLICATION

Overview	27
SMART FACTORY SOLUTION	
- Automatic Measuring System	28
- Powder Packaging System	29
- Liquid Filling System	30
- Tank, Hopper & Silo Measuring System	31
SMART LOGISTICS SOLUTION	
- Logistics Management System	32
- Smart Truck Scale System	33
SMART RETAIL SOLUTION	
- Retail Store Management System	34
- Self-scan/Check out Service	35
SMART FARM SOLUTION	36
SMART LABORATORY SOLUTION	37
SMART AIRPORT SOLUTION	38
Our Partners	39



COMPANY INTRODUCTION

CEO Message

Overview

Management Philosophy

History & Achievements

Organization

R&D

Production Facilities

Global Network

Domestic Network

Service

Happy CAS Day

Certification

01



CEO Message



CAS started as a venture company with the goal of Engineering Automated Robotics in 1983. It is now celebrating its 43rd anniversary. I would like to express my gratitude to all our employees, who have devoted their lives for the growth of the company and to all of those who have trusted and supported CAS over the years.

CAS has become the leading electronic scale industry in Korea, changing mechanical scales into electronic scales. We have transformed the traditional market culture to a modern one, redefining trust in commerce as our slogan said, 'CAS Scales are good for both customers and vendors'. Our interest in sensor technology has expanded to other various physical sensors, measurement instruments, and vision inspection solutions, and is being defined for various industrial environments.

Interest in the global market has resulted in exporting to overseas markets from the early days of CAS. CAS has expanded by founding a factory in China in 2013 to secure competitiveness in the global market where technology and price competitions are fierce. On top of its production capabilities, CAS now has a global network of over 120 countries that continuously grows over time.

The establishment of an overseas infrastructure for CAS is a cornerstone to get closer to customers. CMO (CAS Mobile Office) was established to listen their needs and to provide customized solutions throughout customer visits. These efforts are forming into solutions for production and inspection equipment required for cutting-edge industries ranging from heavy to nanotechnology industries.

Celebrating its 43rd anniversary, CAS is preparing to establish CAS SFC (Smart Factory Complex). We will reorganize our business portfolio with smart factory engineering, gathering data from our sensors required for advancing industries, and pushing our boundaries in robotics solutions to accommodate changes required by the industrial environment.

We always remind ourselves of the venture company mindset set at the start, and value the trust that we have built with our customer as a sensor company. Please keep an eye on us as we continue to strive to become a global leader in sensor and weighing technology.

CEO of CAS Indy(Tae-in) Kim



Overview

CAS is a leading Korean company that leads the standard of commercial and industrial weighing systems based on sensor and weighing technology. 40 Years ago -when disbelief about Weighing scales prevailed- CAS developed and distributed digital electronic scales in the domestic market to receive trust in weighing.

Since its founding in 1983, CAS has acquired major weighing standards with the slogan "We Weigh the World", and has been recognized for its value abroad by exporting to over 120 countries through 11 branches overseas.

Company Name	CAS Co., Ltd.
Date of establishment (IP O date)	April 19, 1983 (December 28, 1989)
CEO	Tae-In Kim
Headquarters location	262, Geurugogae-ro, Gwangjeok-myeon, Yangju-si
Representative Phone number	+82 31 820 1100
Number of employees	786 (including overseas employees)
Business Field	Manufacturing (Electronic scales, Measuring instruments, Weighing sensors, Engineering design, Printed materials)
Affiliates	(Korea) CAS Chemical, CAS E&C, CAS Label
Sales	170 billion won (\$ 134,000,000)
Capital	13.2 billion won (\$10,400,000)
Official Website	(Korea) www.cas.co.kr / (global) www.globalcas.com

* As of the end of 2025



BRAND POWER

Korea No. 1 Brand Power (Digital Scale Category)

CAS has been firmly maintaining No. 1 brand power in the electronic scale category. With 70% of the Korean market share, we are steadily receiving the trust of our customers.



세상의 무게를 만다!

43rd Year Since the Founding of CAS

CAS is Korea's leading brand that has been recognized for 43 years by its domestic capital and technology.



National Service Center Network With 70 Offices

CAS is growing as a customer-oriented company through our 70 service centers including 13 branches in Korea.



135 Globally Certified Weighing Products

CAS has obtained various weighing certifications from countries based on the weight sensor technology.



120 Partner Countries

CAS is a global company that exports its products to 120 countries.



Management Philosophy

VISION & SLOGAN

WE WEIGH THE WORLD

GOAL

The world's leading company for weighing, sensor and measuring instruments.

Management Strategy

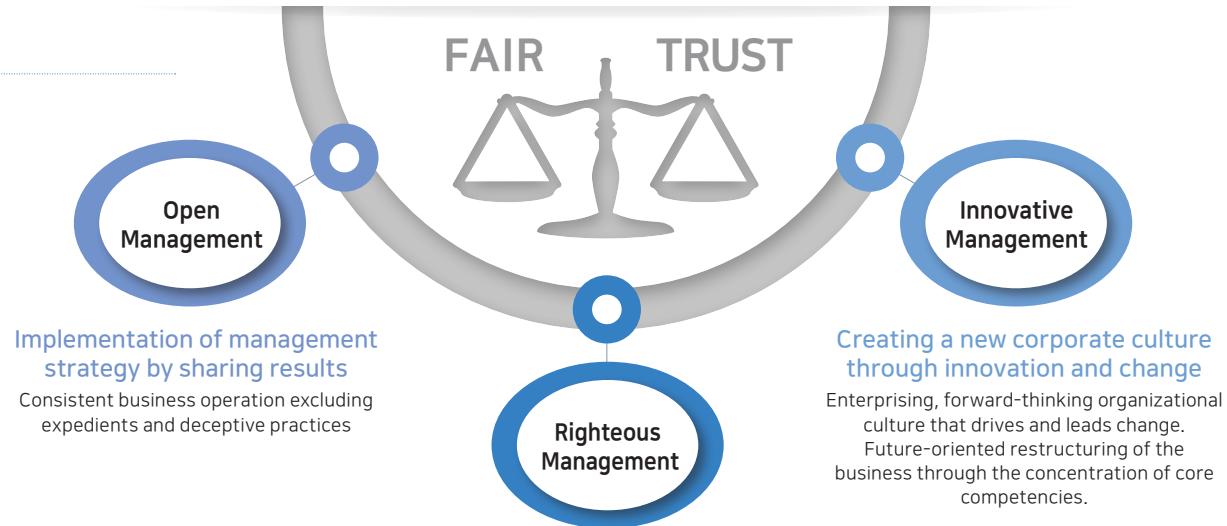



History & Achievements

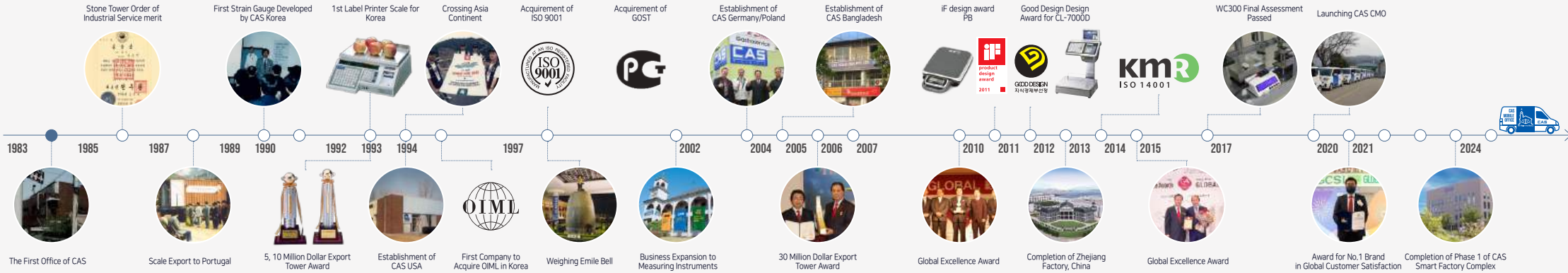

Establishment and Challenge

- 1983 Establishment of CAS Co., Ltd.
- 1985 Order of Industrial Service Merit, Tin Tower
- 1987 Korea's first electronic scale Export(Portugal)
- 1989 Development of the first strain gauge in Korea
Designation of the National Calibration Agency (No 177)
Listed on KOSDAQ
- 1990 Acquirement of NIST U.S. weighing standard

Growth and Globalization

- 1991 Acquirement of UL American safety standard
5 Million Dollar Export Monument Award
- 1992 Korea's first label printing scale development
Establishment of CAS Türkiye
10 million dollar export award
- 1993 Success in transcontinental Asia (Baekdu mountain - Istanbul)
Establishment of CAS USA
- 1994 Korea's first acquirement of OIML
Establishment of CAS China
Establishment of CAS Russia
- 1997 Acquirement of ISO 9001
- 1999 Establishment of CAS India
- 2000 Cumulative production of electronic scale exceeded 1 million units

Business Scope Expansion

- 2001 Selected as the best ISO 9000 certified company for 2 consecutive years
Russia Golden Balance 2002 Award
Establishment of CAS Vietnam
- 2002 Launching CAS measuring instrument business
Scale n-body development
- 2003 JMAC(Japan Management Association Consultants) Global Best Company
- 2004 Establishment of CAS Poland
Establishment of CAS Germany
- 2005 Establishment of CAS Bangladesh
- 2006 Implementation of eco-friendly program
30 Million Dollar Export Monument Award
- 2007 KDB 2007 Global star Award
- 2009 Establishment of CAS Zhejiang in China
- 2010 Global Management Award

Smart Factory Business

- 2011 iF design award 2011(PB)
- 2012 CL7000-D Good Design selection
Prime minister's award at the precision industry technical competition
Establishment of CAS Japan
- 2013 World Class 300 company selection
Completion of Zhejiang Factory, China
Establishment of CAS Chemical
- 2014 Acquirement of ISO14001
- 2015 Global management Award
- 2019 Global Customer Satisfaction Competency Index(GCSI) 1st
Global Brand Competency Index(GBCI) 1st

Innovation Growth to Realize Better Value

- 2021 Global Customer Satisfaction Competency Index 1st
- 2022 Establishment of CAS Mongolia
- 2023 40th Year Since the Founding of CAS
- 2024 Completion of Phase 1 of CAS Smart Factory Complex
KOTRA-Designated Certified Trading Company



Organization

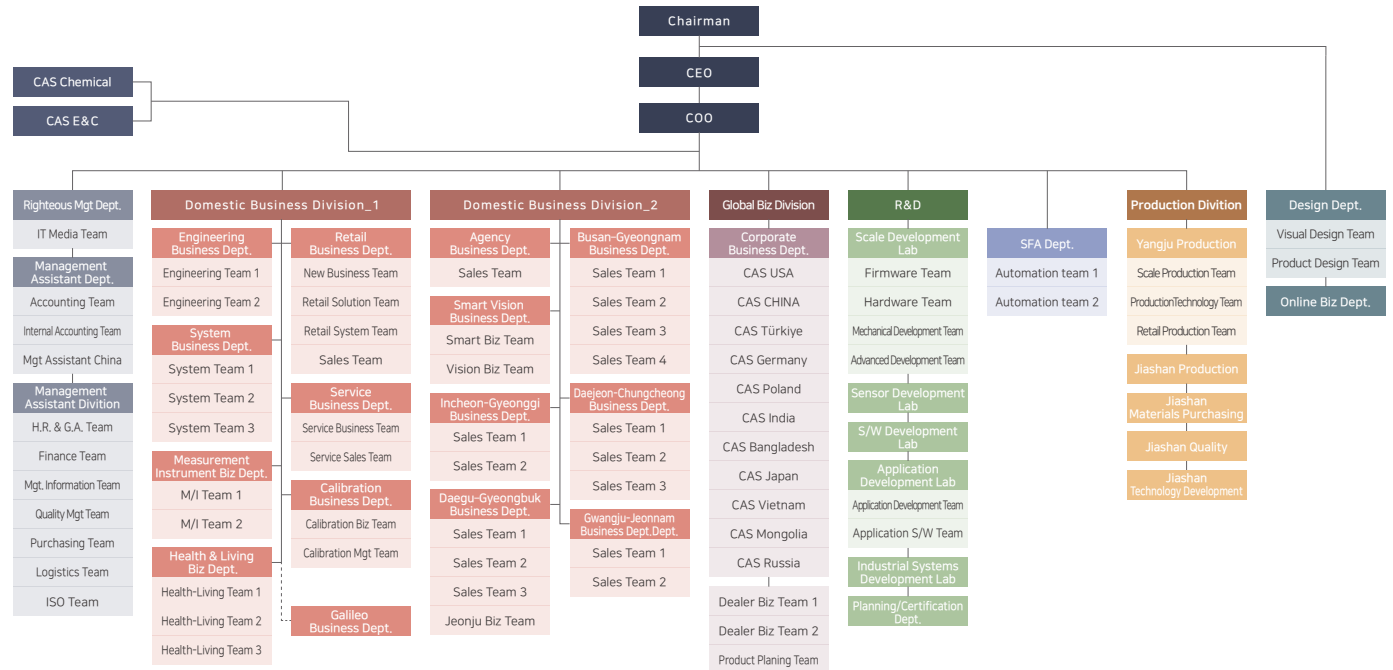



R&D

The starting point of technological innovation, CAS R&D Center

CAS's R&D Center, which is actively conducting research in the fields of electronic scales and sensors, focuses on the overall technological development of CAS and overseas markets.

Core technology for the best weighing measurement solution

CAS firmly believes that the development of products for the business situation of customers and users begins by listening to the customer. CAS is working to develop products that best reflect the needs of the field by implementing an open communication policy that allows the field and research center to share information. In addition, through various partnerships, such as technical cooperations and industry-academic cooperations, CAS achieves technological innovation and provides the best total weighing and measurement solutions to customers around the world.



Development of CAS ONE-CHIP for Fast and Accurate Weighing Performance

The CAS ONE-CHIP, developed by CAS, is a core technology chip that enables fast and accurate weighing, and it is applied to various products developed by CAS.





Production Facilities

Domestic Production Plant

Our production plant in Yangju, which started in 1985, is a historical place for various products ranging from CAS's initial production to the current smart factory and 4th industry products. In the Galileo building, CAS produces strain gauges, which are the core part of weighing sensors load cells. Also, various load cells and indicators are produced and provided to industrial sites. In the main sector, label prints and products for retail and industrial sites are produced. In addition, CAS is an official KOLAS calibration agency and operates a calibration center that enables maintenance and calibration in Yangju.



Global Production Plant

CAS' global production plant develops products for various industries to realize a total weighing solution. Building A produces label printing scales, various retail products, simple weight scale, counting scales, counting scales, small industrial products, and scales for research. Building B produces customized products and industrial products such as platforms. Building C produces system products such as can fillers and packing machines and provides solutions for logistics and factory automation.





Global Network

Since its foundation in 1983, CAS has acquired major weighing certificates in major countries, and has sold products to over 120 countries through 11 overseas corporations and branches. Furthermore, it plans to strengthen overseas business, and pursue business stability through localization strategies.

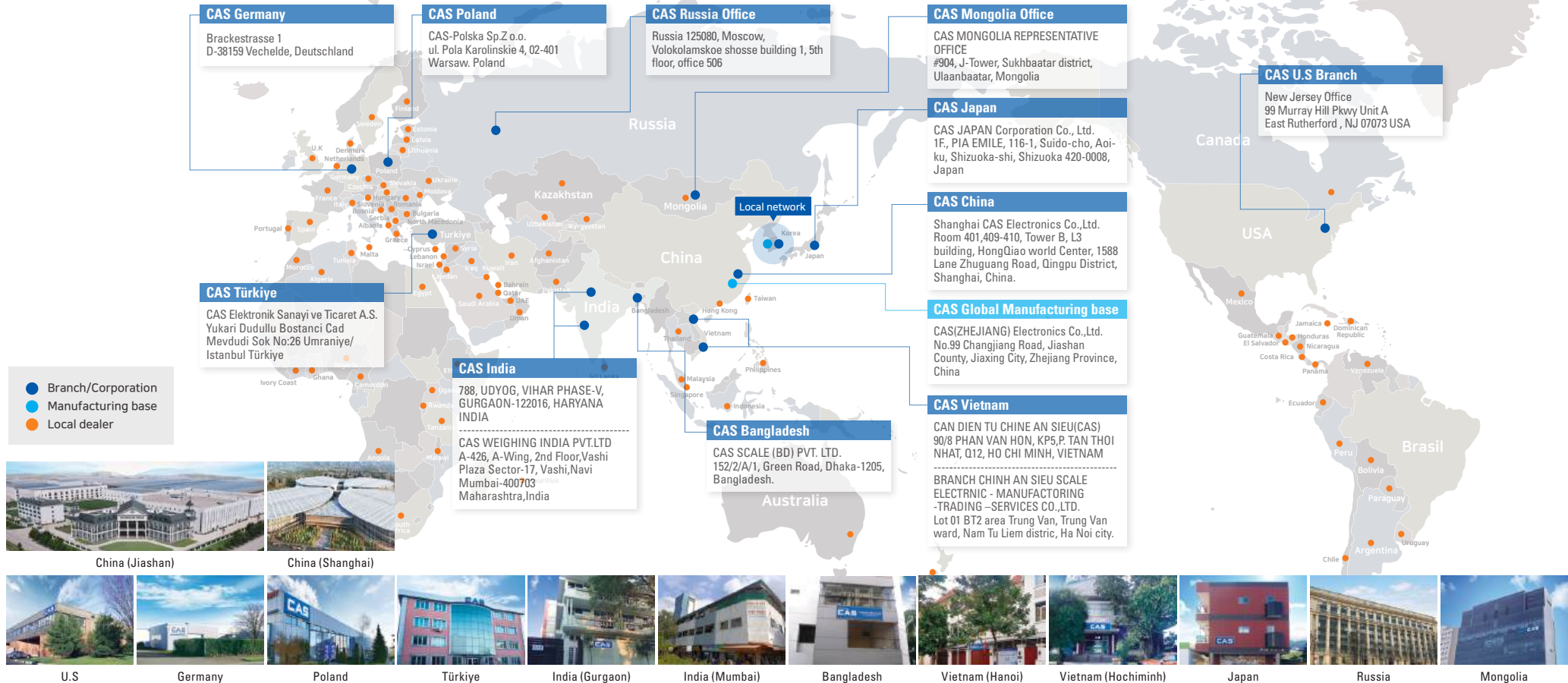



Domestic Network

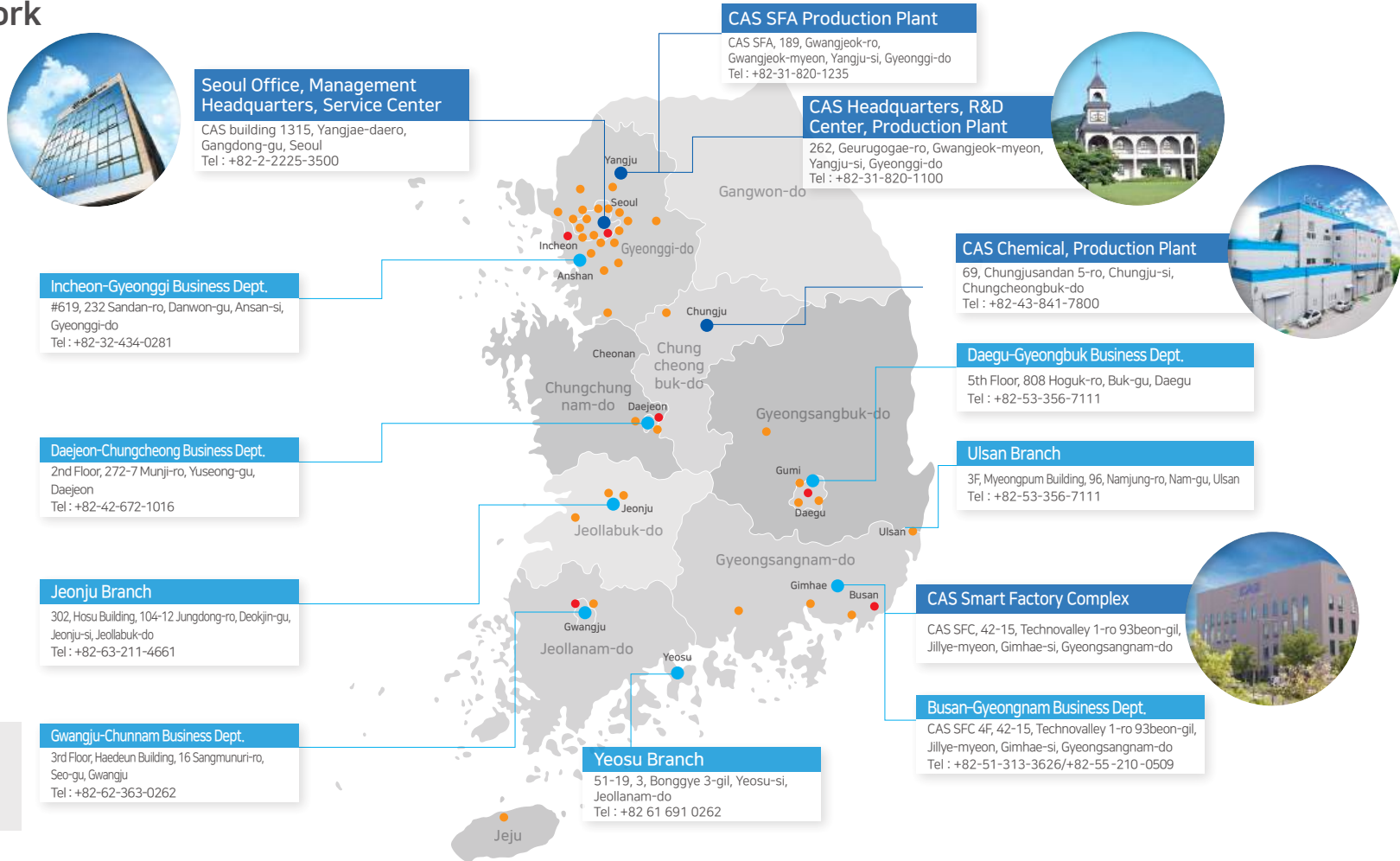



Service (CAS Galileo Marketing)

In order to gain customer customers' trust, CAS provides technology-driven close-up services to give convenience and benefits to customers at regional local headquarters.

CMO (CAS Mobile Office)

Visiting Service - CAS Mobile Office

Our CAS Mobile Office is the answer to all weighing and measurement requests of customers. CMO maintains close relationships with local customers, while serving as a bridge between regional, national and global companies. It is an activity that services products through regular customer visits, maintains product reliability, and increases customer satisfaction.



CTS (Calibration Traceability System)

CAS Traceability System

CTS is a calibration history management system for scales, and it is a system to efficiently and systematically manage regular inspections and calibrations of scales.



Tracking of installed scales



Location information of installed scales



Alarm service for calibration term





Happy CAS Day

Happy CAS Day is a customer appreciation program held in celebration of CAS's founding anniversary and CAS Family Day. It is CAS's representative nationwide on-site program, in which CAS teams visit various workplaces where CAS products are in use and provide weight accuracy inspections and product cleaning services for customers' CAS equipment.

This event goes beyond simple service delivery. By engaging directly with customers who use CAS products in real working environments, CAS verifies product accuracy and reliability while listening firsthand to customer feedback and improvement requests. These insights serve as a foundation for identifying future directions to enhance product quality and ease of use.

Through Happy CAS Day, CAS actively reflects the voice of customers gathered from the field in its product development and service policies, striving to continuously deliver weighing solutions that meet market needs.

Happy CAS Day is a meaningful on-site initiative in which all CAS employees come together to communicate with customers at the closest point of contact, putting into practice CAS's philosophy as a professional weighing and measurement company that places the highest value on trust and accuracy.





Certification

WE WEIGH THE WORLD



OIML Certification
95 Products

인증제품 현황

SW-1 Series, SW PLUS Series, ER JR Series, PW-II, AD, AP PLUS / AD PLUS Series (1M), AP Series, BW Series, BW-1, CASTON Series (1M), CAU Series, CL5000 / CL5000J Series, CL5200 Series, CL5200N Series, CL5200-xN Series, CL5000 Series, CL7200 Series, CL7200-D Series, CT100 Series, UW / UX / XB Series, DB-1H, DB-II, DB-IIIF, Dolphin Series (OMV2), Dolphin Series (OMV4), EC Series, SW Series (OMV2), SW Series (OMV4), ER Series, FW500 Series, HS Series, HS-2, LP / LP-1 / LP-1.6 / LP-1.7 / LP-T / XP, LP-II, MP Series, AW / AX / AY, PB (1M), PBI, PD-II, POscale, PR PLUS Series, SP-1, SW Series, SW-1, SWII PLUS Series, SWII Series / PRII Series, SWII-B / PRII-B, P, U, D, TP-1, TP-II, XE Series, XE PLUS Series, CI-2000 Series, CI-2001 Series, CI-200 Series, CI-600A / CI-600D Series, CI-600 Series (CI-600A MID), NT-500, PDI / PDI-S, RW-5000 Series, BC0-xxL, BCW-xxL, BCA, BCB-xxxL, BC-xxxxF, BCL, BCL5-xx, BCN / BCM, BCS, BSA_High, BSA_Low, BSS / BSSC, DSB1, HBS, SBA, SS-xt, WBK / WBS, WBK-D, CL8000-PCX / CL8000-B / CL8000-SU / CL8000-U, PB (OMV4), PDN-ccxx Series, CL5500 Series, CL5200J Series, CL3000 Series, CL8000 Series, CI-170A, CN1 Series, CASTON-II PLUS series, CL5500N Series, CT100N series, CB Series, CI-10XA series, SWN, ER, JR, ER PLUS



NTEP Certification
40 Products

Product List

R320, R323, X320, R400 Series, R420, R423, R427 and R 457, PDN-cc, RW-PL Series, CL 3000 Series, CL 5000 Series and CL 5500 Series, BCM Series, SS-xk Series, BSS Series, BCA-XL Series, SBA Series, BSA, BSAC and BSAP Series, DL Series, FW500 Series, CL7200 Series, DSB1 Series, GW-XXX, CI-100A, SW-5, SW-10, SW-20, SW-50 & SW-RS, PD-I, PD-II, CI-2001 Series, BW Series, LP-1000, NC-1, AP-1, S-2000, ER JR xxB & ER JR xxU, EB Series, SW-1W, ED Series, S2000 Jr, HCMS-x & HCS-x Series, Enduro DXL-10xxx, Enduro DXL-12xxx and Enduro DXL-15xxx Series, X320, R420 and R423, PB, CI-200A, CI-201A, CI-200S and CI-200SC, CPS-1, CPS-2, HFS74xx & HFS-5xx Series, RW-10L / RW-05L / RW-10S / RW-05S



CE Certification
110 Products

Product List

SW-1 Series, SW PLUS Series, PW-II, CK-200 Series, PDS-5, PD-FS, CI-400 Series, CL5500 Series, CL5200J Series, CL5500 Series(한국), AD PLUS, AN-4212S, AP PLUS Series, BCL-60L, BC-x00PA-EXP, BW-1N Series, CASTON II PLUS-C Series, CASTON II PLUS-E Series, CASTON IIB) Series, CASTON III PLUS(B)-xx Series, CASTON-H, CC-ER Series, CD-3010A, CI-150A, CI-170A, CI-200A Series, CI-200A/HF5xxx Series, CI-200 Series, CI-400AL Series, CI-600A Series, CI-1500A, CI-1560A, CI-2001 Series, CL3000 Series, CL5200 Series(무선), CL5200 Series(무선), CL5200N Series, CL5200 Series, CL5200J Series, CL7200 Series, CL7200 Series, CL7200 Series(무선), CL8000 Series, CLM-xxx Series, CRS-100, CS, CSD-1, CT100 Series, DB-1H PLUS(OMV4), DBII-C(OMV4), DBII-E, DBI/SPS Series, DD, DD/SPS, DSB-D, EB Series, EBI Series, ED(OMV4), ER PLUS Series(OMV4), ER-JR Series(OMV4), FW500 Series, HC-D, HC-ER Series, HD, HDI, LP-1.6, LS Series, LS-D, LSS Series, MP Series, CPS PLUS, NT-200 Series, PBI(OMV4), PBI, PDC, PDI, PD-I, PD-II Series, PDN Series(무선), PDS-E, PDS-I+M, PDS-S, PDI-S, PR-C, PRII Series, RS9110-N-11-22, RW5000-P SW-1WR/SW-1LR, SW-1WR/SW-1LR(OMV4), SWII PLUS Series, JF005WR Adaptor Series(SWII Series, PRII Series), SWII Series(LCD), SWII Series(LED), THZ, TM, WBK-ER, WBK-xxD, AD, AP-1 Series, EXI-200AD Series, EXH-600AD Series, CN1 Series, CB(CBB)CI-100A/SPS series, CI-100A series, CCK-700 series, CL5500N Series, CLM-xxx, CT100N Series



UL Certification
27 Products

Product List

LP-II, TP-1, PD-1, AP-1, LP-1000 60M, 30M, 15M, S-30, S-15, S-50C, S-25C, S-10C, 300AM, 150AM, 60AM, 250AC, 100AC, 50AC, 50CS, 25CS, 10CS, 5CS, 60D, 30D, 15D, 6D, LP-II, S-2000, S-2000-60, AP-1, CAS-100, LP-1000, PD-II, DB-II, LP-IIIF, ER PLUS-xxC, ER PLUS-xxCP, ER PLUS-xxMCP, ER PLUS-xxCU, ER PLUS-xxCB, ER PLUS-xxCBB, ER PLUS-xxMCCBP, ER PLUS-xxCBBU, ER PLUS-xxE, ER PLUS-xxEP, ER PLUS-xxMER, ER PLUS-xxEU, ER PLUS-xxF, ER PLUS-xxFP, ER PLUS-xxFU (xx can be 06, 15 or 30), PD-II(6 kg), PD-II(15 kg), PD-IIR(6 kg), PD-IIR(15 kg), PD-IIR(15 kg), PD-IIR(30 kg), PD-IID(30 kg), PD-IIR(60 kg), PD-IID(60 kg), PD-IIR(60 kg), PR PLUS-XXB, PR PLUS-XXP (XX can be 06, 15, 30), CL5000J-C Series, CL5200 Series, CL5200 series, CL5200J series, BC-200PA-2W, BC-200PA-3W, BC-200PA-EXP

Quality

The production system of CAS is based on ISO9001 and ISO14001 certifications. CAS is the first Korean company with self-calibration, and with European autonomous testing. CAS has established and operated a systematic production process through a strict quality control system.





OUR BUSINESS

Sensor Solution

Industrial Weighing Solution

Laboratory Weighing Solution

Retail Weighing Solution

Measuring Instrument Solution

Health & Living Solution

Calibration Solution

CAS Mall

CAS CHEMICAL

02



Sensor Solution

CAS is providing optimized solutions for industrial environments based on the unique strain gauge and force sensor technology in the domestic market. It supports various sensor application technologies in the era of smart factories, including explosion-proof weighing industries, precision weighing industries, safety diagnostics of mechanical facilities, safety diagnostics in the construction and civil engineering fields, and quality management.

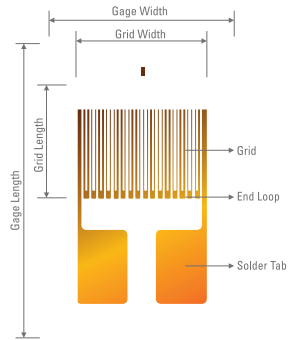

Strain Gauge

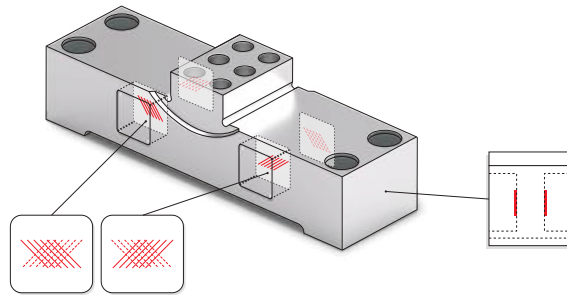

Load cell

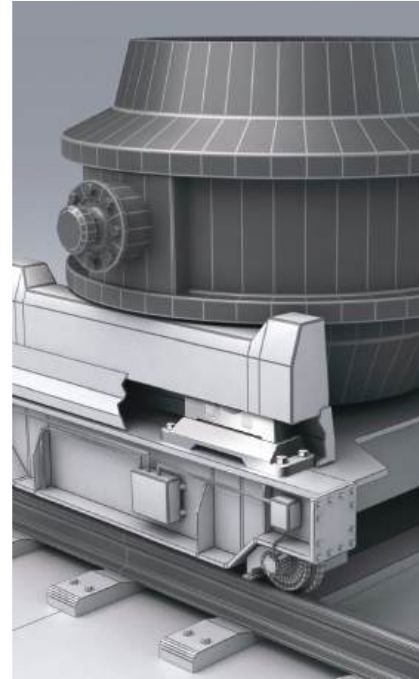

Explosion Proof Load cell

Digital Load cell

Noise resistance Load cell

Single Point Load cell

Single ended beam Load cell

S-beam Load cell

Disk type Load cell

Double ended beam Load cell

Canister Load cell

Platform Load cell

Special Load cell

Weighing Controller



Industrial Weighing Solution

The ultimate goal of CAS is to realize the core values of the industrial system: efficiency and stability. We provide the systems needed for all industries from various manufacturing processes, line processes, packaging processes and logistics processes.

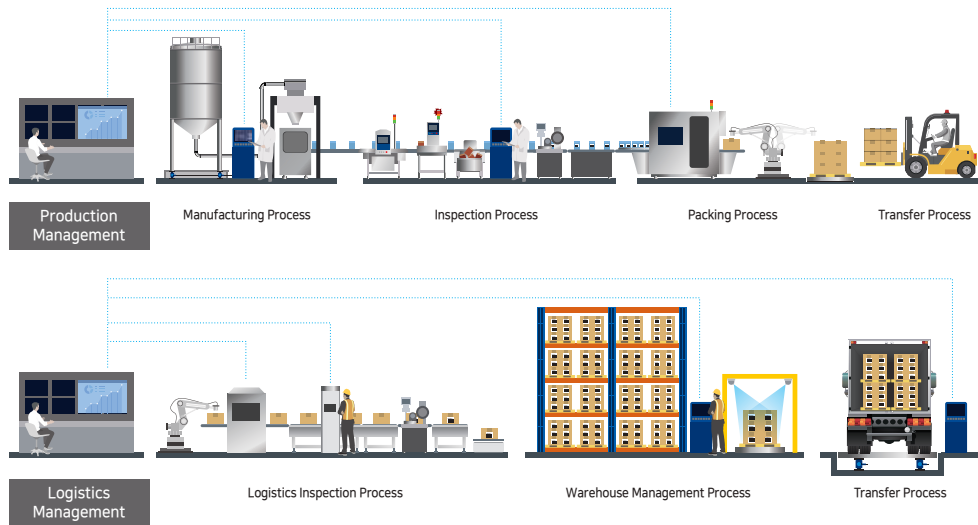

Counting Scale



Bench Scale



Portable Bench Scale



Platform Scale



Pallet Scale



Fork Lift Scale



Exp Mobile Weighing

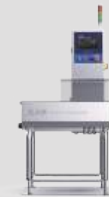

Checkweigher



Metal Detector



Liquid Filling Machine



Auto Labeler



Packaging Machine



Laboratory Weighing Solution

CAS provides solutions for the measurement and counting of various industries, including research laboratories, experimentation facilities, and the blending and quality management of raw materials in the electrical/electronic components industry. These solutions are built on outstanding technological capabilities and products that have passed rigorous specifications.



Micro Weighing Scale MWII PLUS



Analytical Balance
CAT



Analytical Balance
CAU



Precision Balance
CBL



Precision Balance
CU



Precision Balance
CBX



Micro Weighing Scale
XE PLUS



Micro Weighing Scale
MWII-H



Micro Weighing Scale
MW-III



Moisture Analyzer
XC63



Weight Sets



Retail Weighing Solution

CAS embodies the core values of commerce. It plays a role in completing the transaction process with consumers in various business environments. In the field, it fulfills the role of measuring accurate product weights and prices.



PC Based Scale CL8000-U



PC Based Scale CL8000-PCA



Label Printing Scale CL7200-D



Label Printing Scale CL3000-P



Basic Scale SW-II



Scanner-Ready Scale PDS-II



Price Computing Scale AP-1



Fruit Sorter FS-250

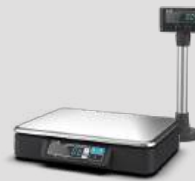

ECR Interface Scale PDN



Waterproof scale SWII-W



Scanner



Printer



Consumables Label, Ribbon



Measuring Instrument Solution

CAS Galileo, CAS's brand specializing in precision instruments, seeks comprehensive precision measurement solutions around the world. We are working with famous instrument brands around the world to provide convenience with more diverse products.



Physical and Chemical Appliances



Density Meter



Viscometer



Environmental Measuring Instruments
(Sound Level Meter, Anemometer, Lux Meter, Temperature & Humidity Meter)



Salinity Meter



Brix Meter



Ionizer



Particle Counter



Residual Oxygen Meter



Heat Index Meter / Data Logger

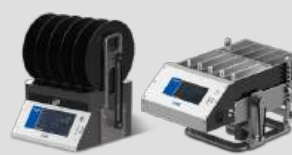

Rota-rod/Tread mill



Electrostatic



Water Quality Meter



Thermal Imaging Camera



Health & Living Solution

CAS Health & Living is a brand that has essential household items for family health care and home environment. CAS Health & Living offers a variety of solutions for a healthy life.



MEDICAL

HEALTH



BEAUTY

KITCHEN APPLIANCES



BABY CARE

HOUSEHOLD APPLIANCES



8 Electrodes Body Fat Analyzer



Digital personal scale



Kitchen scale



Food Thermometer



Thermo-Hygrometer



Timer



Electric pot



Ultrasonic Washer



Blood Pressure Monitor



Ultrasonic Nebulizer



Thermometer



Calibration Solution

CAS calibration solutions have calibration equipment with traceability of national standards and provide a wide range of calibration services with technical capabilities.



A total service solution that provides everything related to measuring and metering
National Accredited Calibration Institution CAS

CAS is a KOLAS certified calibration institution, officially declared as having capable calibration technology by an evaluator registered in accordance with the standards set by the International Standards (KS Q ISO/IEC 17025) and the Korea Laboratory Accreditation Scheme (KOLAS).

KOLAS Accreditation No.: KC02-090
Scope of Accreditation: 201. Mass / 202. Force / 501. Temperature / 503. Humidity



Calibration Equipment



Deadweight (300N)



Deadweight (1.5kN)



Force calibration machine (200kN)



Deadweight (1-5kN)



Deadweight (250kN)



Deadweight (50kN)



Crane (7.5t)



E-commerce, CAS Mall



CAS Mall is the official online shopping platform of CAS, a specialized manufacturer of weighing and measurement sensors. It offers a wide range of weighing and measuring products—including electronic scales—along with related solutions, all in one place.

With a comprehensive product lineup covering industrial, commercial, laboratory/research, and everyday applications, CAS Mall helps customers select the most suitable products based on their specific usage environments and purposes.

As a manufacturer-operated online store, CAS Mall provides accurate product information, reliable quality, and seamless after-sales service support, ensuring a convenient and trustworthy purchasing experience. In addition, through the latest product updates, technical information, and various promotional activities, CAS Mall continuously engages with customers, allowing them to experience CAS's technological expertise and professionalism online as well.

<https://www.cas-mall.com/>



Electronic Scale



Load Cell / Sensor



Indicator



Measuring Instrument



Tools



Printer



Custom-Made Product



Consumables



CAS CHEMICAL [TTR/Label]

CAS Chemical is the only coating specializing company that uses Korean materials and technology. We have developed our own ink and back coating liquid technology, and it has been accepted as the best. We have developed our products to minimize damage caused to printed heads to decrease costs and efforts needed to replace them. We are also doing our best to maintain the best quality in our printing quality, durability, static prevention, printing speed, compatibility, and label adaptation value.



Thermal Transfer Printer, Printer head



Ribbon / Label / Sticker



Thermal Transfer Ribbon

- Standard Wax Ribbon for Flat Head
- Wax/Resin Ribbon for Flat Head
- Resin Ribbon for Flat Head
- Wax/Resin for Edge Head
- Resin for Edge Head
- Wash Care Resin Ribbon

Thermal Transfer Printer/Printer Head/Label Issuing Program





SYSTEM APPLICATION

OVERVIEW

SMART FACTORY SOLUTION

- Automatic Measuring System
- Powder Packaging System
- Liquid Filling System
- Tank, Hopper & Silo Measuring System

SMART LOGISTICS SOLUTION

- Logistics Management System
- Smart Truck Scale System

SMART RETAIL SOLUTION

- Retail Store Management System
- Self-scan/Check out Service

SMART FARM SOLUTION

SMART LABORATORY SOLUTION

SMART AIRPORT SOLUTION

MAJOR PARTNERS

03



CAS makes a smart world based on sensor technology.

With the advent of the Fourth Industrial Revolution, efforts are being made to transform traditional industrial sites into smart factories in various industrial sectors. The smartification of manufacturing processes is crucial and involves precise information gathering through sensor data and history management using big data. CAS leverages high-quality sensor technology to enhance productivity and quality in various industrial fields and supports the smartification of industrial facilities based on big data by collecting real-time data across various sources.

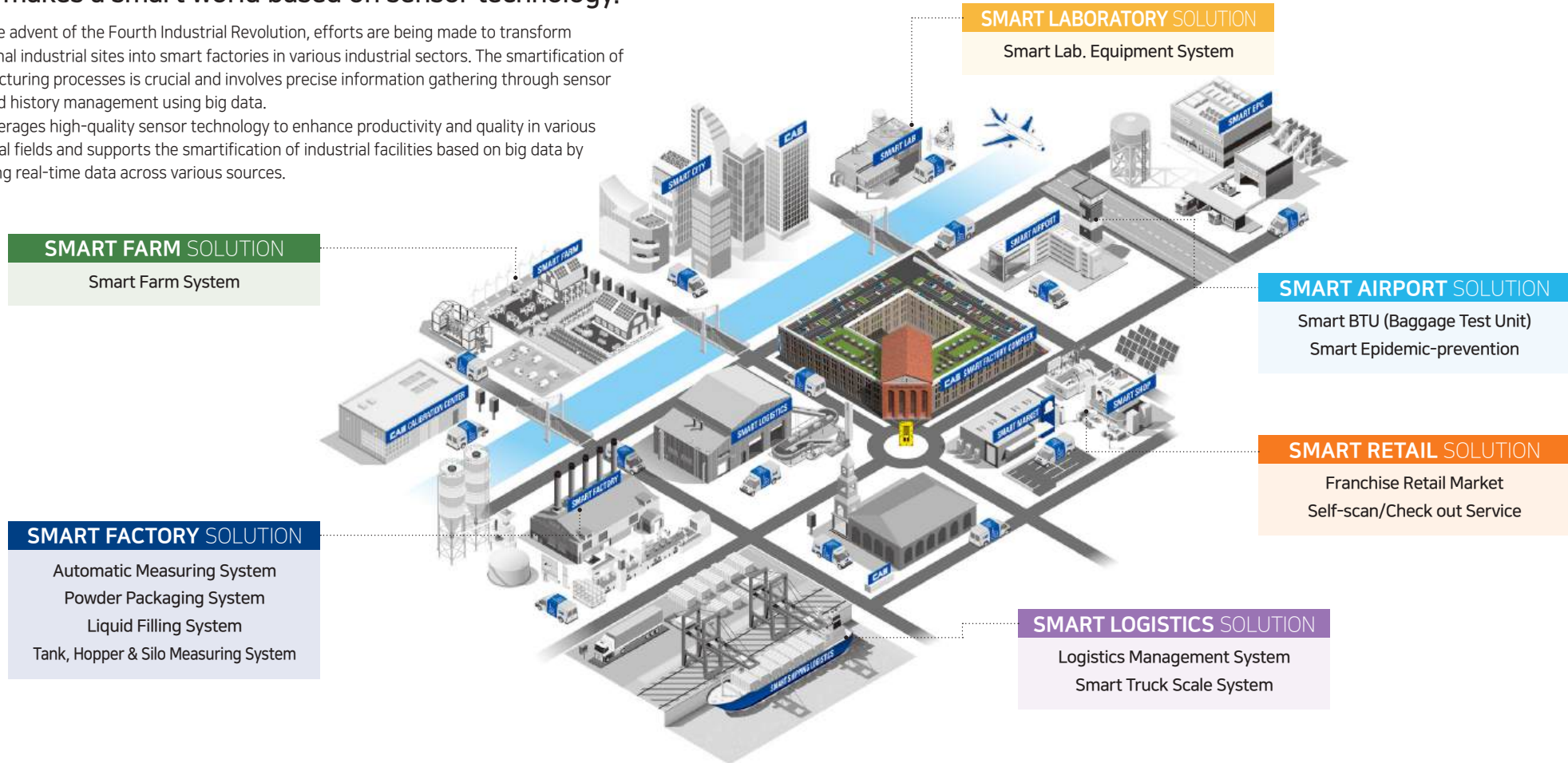



SMART FACTORY SOLUTION

AUTOMATIC MEASURING SYSTEM

The CAS Automatic Measuring System automates each process from the incoming materials to the outgoing products, including weighing, counting, inspection, packaging, quality checking, and labeling. This automation reduces work time and addresses labor shortages. Furthermore, it contributes to the safety and reassurance of products by real-time monitoring of the manufacturing history and distribution process.



Combination Meter



Rotary Packaging Machine



Packaging Machine



Metal Detector



Checkweigher



X-Ray



Rejector



Auto Labeler



Ionizer



Automatic Enclosure



Automatic Sealer



Automatic Wrapping Machine



SMART FACTORY SOLUTION

POWDER PACKAGING SYSTEM

The CAS Powder Packaging System is designed for powdery materials such as flour, cement, fertilizer, and feed. The system fills predetermined packaging containers with the powdery substance, seals them, performs quantity verification, foreign material inspection, and loads the specified amount onto pallets for shipment.



Silo



Bagging Packer



Sealing Machine



Metal Detector



Checkweigher



X-Ray



Rejector



Pallet Feeder



Robot Arm



Automatic Wrapping Machine



Forklift Scale



- Overview
- Automatic Measuring System
- Powder Packaging System
- Liquid Filling System**
- Tank, Hopper & Silo Measuring System
- Logistics Management System
- Smart Truck Scale System
- Retail Store Management System
- Self-scan/Check out Service
- Smart Farm Solution
- Smart Laboratory Solution
- Smart Airport Solution
- Major Partners



SMART FACTORY SOLUTION

LIQUID FILLING SYSTEM

The CAS Liquid Filling System is designed for liquid substances such as water, beverages, oil, and chemicals. This system fills various containers with liquids, including sealing them, performing quantity verification, conducting leak tests, and loading the specified amount onto pallets for shipment.



Silo



Liquid Filling Machine



Capping Machine



Auto Labeler



Checkweigher



X-Ray



Rejector



Loading Robot



Automatic Sealer



Inkjet Marker



Forklift Scale



SMART FACTORY SOLUTION

TANK, HOPPER & SILO MEASURING SYSTEM

To measure the contents of industrial tanks, hoppers, or silos, an accurate weighing system is necessary. An effective weighing system can be configured by using multiple high-capacity load cells in conjunction with a precise weighing indicator. Additionally, depending on the operating environment, applying explosion-proof products and vibration-resistant design to the weighing module provides a safe weighing management solution.



Silo



Explosion-proof Load cell

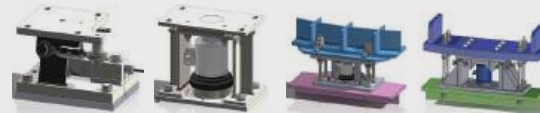

Customized Load cell & Mount



Explosion-proof Indicator



SMART LOGISTICS SOLUTION

LOGISTICS MANAGEMENT SYSTEM

The CAS Logistics Management System is a comprehensive solution that integrates various sensors, weighing, measuring, and PC-based equipment (Weighing + Measuring + PC), along with dedicated control programs. It efficiently operates real-time logistics and inventory management by interconnecting these components. From the moment products are received, the system automates processes such as weighing, counting, packaging, inspection, sorting, labeling, and more, resulting in reduced work time and maximized efficiency.



Barcode Scanner



Logistics Inspection System



Rejector



Auto Labeler



AGV



Palette Scale



Cart Scale



Printer



Platform Scale



Scanner



Forklift Scale



Overview

Automatic Measuring System

Powder Packaging System

Liquid Filling System

Tank, Hopper & Silo Measuring System

Logistics Management System

Smart Truck Scale System

Retail Store Management System

Self-scan/Check out Service

Smart Farm Solution

Smart Laboratory Solution

Smart Airport Solution

Major Partners



SMART LOGISTICS SOLUTION

SMART TRUCK SCALE SYSTEM

The CAS Smart Truck Scale System is a user-friendly, high-performance, and scalable solution designed for use in manufacturing plants, transportation companies, waste disposal, and recycling facilities. It is utilized for managing the weights of incoming and outgoing shipments, as well as material flow in recycling facilities. Through unmanned operations, it ensures the reliability of weighing information and can be easily integrated with ERP systems, providing a convenient and efficient solution.



Truck Scale



Load Cell



Indicator



Remote Display



Unmanned Weighing System



Plate Number Recognition System



Vehicle Barrier



CCTV



Stoplight



- Overview
- Automatic Measuring System
- Powder Packaging System
- Liquid Filling System
- Tank, Hopper & Silo Measuring System
- Logistics Management System
- Smart Truck Scale System
- Retail Store Management System**
- Self-scan/Checkout Service
- Smart Farm Solution
- Smart Laboratory Solution
- Smart Airport Solution
- Major Partners



SMART RETAIL SOLUTION

RETAIL STORE MANAGEMENT SYSTEM

The CAS Retail Store Management System, based on a cart-type self-scanner system, provides a flawless payment experience with double-checking shopping lists through weight and cameras, ensuring no losses. It offers customization options for various forms of supermarket management systems, including headquarters integrated systems for large retail stores and individual store-level systems. CAS is presenting a vision for the future of retail stores.



Self Check-out



POS Scale



POS



Scanner Scale



Self Scale



Label Printing Scale



Scanner



Automatic Wrapping Machine



Printer



Recycling Scale



Consumables Label, Ribbon



- Overview
- Automatic Measuring System
- Powder Packaging System
- Liquid Filling System
- Tank, Hopper & Silo Measuring System
- Logistics Management System
- Smart Truck Scale System
- Retail Store Management System
- Self-scan/Check out Service
- Smart Farm Solution
- Smart Laboratory Solution
- Smart Airport Solution
- Major Partners



SMART RETAIL SOLUTION

SELF-SCAN/CHECK OUT SERVICE

The CAS Super Smart Self-Checkout Service allows store access through a mobile app or scanner. For consumers, it offers a spacious and autonomous shopping experience with a convenient payment service through the unmanned checkout system. For store owners, it enables smart store and inventory management through consumer analysis data.





Overview

Automatic Measuring System

Powder Packaging System

Liquid Filling System

Tank, Hopper & Silo Measuring System

Logistics Management System

Smart Truck Scale System

Retail Store Management System

Self-scan/Check out Service

Smart Farm Solution

Smart Laboratory Solution

Smart Airport Solution

Major Partners



SMART FARM SOLUTION

SMART FARM SYSTEM

The CAS Smart Farm Solution is a system that creates an optimal growing environment through the collection of environmental data for crops. With this solution, greenhouse environment and crop data can be managed anytime, anywhere. By utilizing a substrate weight sensor compatible with cloud services, it is possible to increase productivity.



Badge Management System



Disaster Detection Drone



Truck Scale



Cattle Weigher



Crude-oil Weigher



Automatic Ton-back Scale



Grain Sorting Machine



Crop Packing Machine



Checkweigher



Bench Scale



Fruit Sorter



SMART LABORATORY SOLUTION

SMART LAB. EQUIPMENT SYSTEM

CAS Smart Research Instrument System is composed of proven research and laboratory equipment based on advanced technological capabilities and strict quality standards. It provides an optimized integrated solution for raw material formulation, process control, and overall quality management across a wide range of industrial applications—including research institutes and laboratories as well as weighing and measurement of electrical and electronic components.



DV-WORKS Software: Program that connects to the viscometer to collect and manage measurement information



- 
Analytical Balance
- 
Moisture Analyzer
- 
Viscometer
- 
Hydrometer
- 
Centrifuge/
Vortex Mixer
- 
Homogenizer
- 
Tensile & Compression
Testing Machine
- 
Drying Oven
- 
Constant Temperature
Water Bath
- 
Temperature &
Humidity Chamber
- 
Disintegration
Tester
- 
Laboratory
Furniture
- 
Particle
Counter



- Overview
- Automatic Measuring System
- Powder Packaging System
- Liquid Filling System
- Tank, Hopper & Silo Measuring System
- Logistics Management System
- Smart Truck Scale System
- Retail Store Management System
- Self-scan/Check out Service
- Smart Farm Solution
- Smart Laboratory Solution
- Smart Airport Solution**
- Major Partners



SMART AIRPORT SOLUTION

SMART AIRPORT SYSTEM

CAS Smart BTU (Baggage Tracking Unit) measures the weight and volume of luggage within the airport, providing various services and advertisements tailored to different airlines. Additionally, through the Smart Epidemic Prevention System, it detects individuals with fever symptoms early on, sharing this information with health authorities and airport authorities, contributing to the creation of a safe and smart airport.



Smart BTU managing S/W



Smart Epidemic Prevention S/W



Smart BTU(Baggage Test Unit)

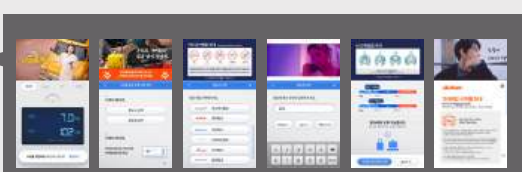

Smart Epidemic Prevention System (Facial Recognition and Temperature Detection)





Overview

Automatic Measuring System

Powder Packaging System

Liquid Filling System

Tank, Hopper & Silo Measuring System

Logistics Management System

Smart Truck Scale System

Retail Store Management System

Self-scan/Check out Service

Smart Farm Solution

Smart Laboratory Solution

Smart Airport Solution

Major Partners





CAS Co., Ltd.

Headquarters : 262, Geurugogae-ro, Gwangjeok-myeon, Yangju-si, Gyeonggi-do
Seoul Office : CAS Building, 1315, Yangjae-daero, Gangdong-gu, Seoul

<http://www.globalcas.com>