

Owner's Manual

CPS-Series

Pallet Scale

Table of Contents

1. PREFACE.....	4
2. DIMENSIONS.....	5
3. SPECIFICATIONS.....	6
4. OPERATIONS	7
5. HOW TO CHARGE	8
6. FRONT PANEL.....	10
7. SET MODE.....	12
8. ERROR MESSAGE AND TROUBLE SHOOTING	16

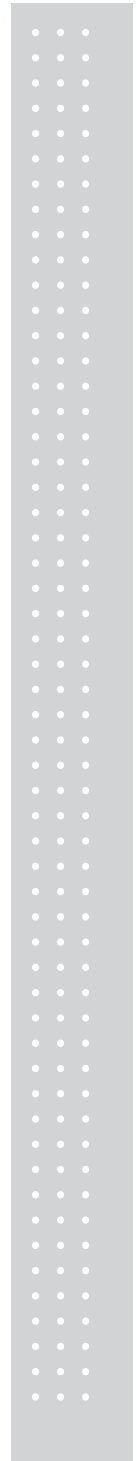

1. PREFACE...1

Thank you for the purchasing of our CAS CPS Series.

These series have been designed with CAS reliability, under rigid quality control and with outstanding performances. Your speciality departments can enjoy with these high quality reliable CAS products.

These electronic load cell scales eliminate the all the moving parts and furnish an accurate digital display of all information.

We believe that your needs will be satisfied and you will have proper reliability in variable weight.

This manual will help you with proper operations and care of the CPS scales.

Please keep it handy for the future references.

FEATURES

CAS PALLET SCALE (CPS) weigh the pallet loads with accuracy.

CPS's "lift and read" technology speed the loading and weighing process.

We have 1000kg and 2000kg capacity models.

Digital indicator displays the weight.

Built-in printer (optional) You can record the weight of loads with printer.

Built-in battery. you can use this scale without power outlet.

NOTICE : Specifications are subject to change for improvement without notice.

CAUTIONS

Do not press the keys hardly, for the keys are in operation with soft touch.

Do not use ignitable material for cleaning.

Keep away CI-2001B from the rain.

Avoid sudden temperature change.

Do not install CI-2001B in a place with high voltage and excessive electrical noises.

Keep it in dry place.

Do not use under direct rays and dusty place.

Do not use at the place with excessive electrical noises and vibration.

2. DIMENSIONS

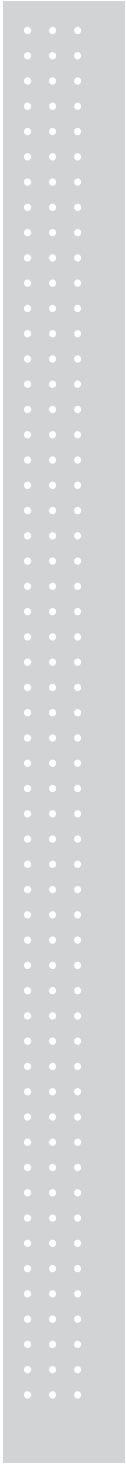
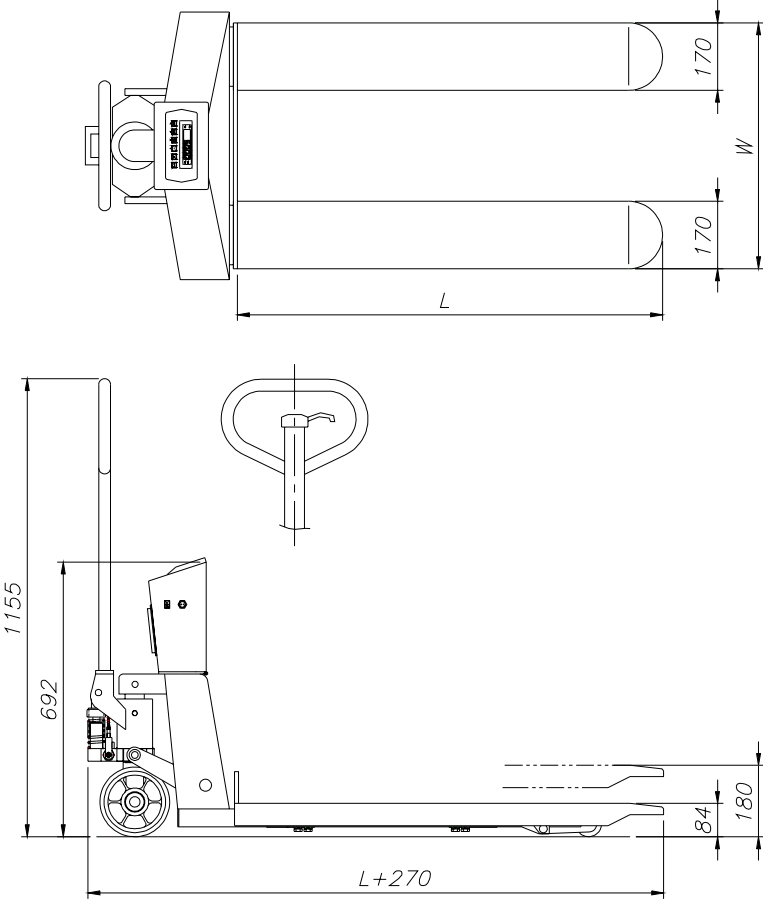

3. SPECIFICATIONS

MODEL NAME		CPS-1			CPS-2		
SIZE	TYPE	A	B	C	A	B	C
	W	540	620	705	540	620	705
	L	1080	1080	1200	1080	1080	1200
CAPACITY		1000 kg ×0.5 kg			2000 kg×1 kg		
OVERLOAD PROTECTION		1500 kg			2500 kg		
WEIGHT DISPLAY		5digit LCD (HEIGHT 25mm)					
POWER SUPPLY		DC6V/ 10AH BATTERY (AC 110V/220V CHARGER)					
ACCURACY		0.1%					
OPTION		PRINTER					
TEMPERATURE RANGE		-10 ~ 40					

4. OPERATIONS

1. Turn the power switch ON.
The power switch is located on the right side of the indicator.
WARNING : Avoid leaving **ANY** load before turn the power switch ON.
2. Display will show “0”, make sure that ZERO lamp is ON.
3. When the FORK lift the load, weighing is performed.
WARNING : Fork have to properly level so as to center bubble of the leveling gauge inside the indicated circle and fork truck should not move.
4. If you want to adjust zero range, press the ZERO key.
5. If you want to use tare function, press the TARE key.
If you don't want to use tare function any more, remove the container(pallet) and press the TARE key.
6. If you want to down the fork, pull the DOWN LEVER.
If you want to lift the fork, press the STOPPER and operate the LIFT HANDLE.

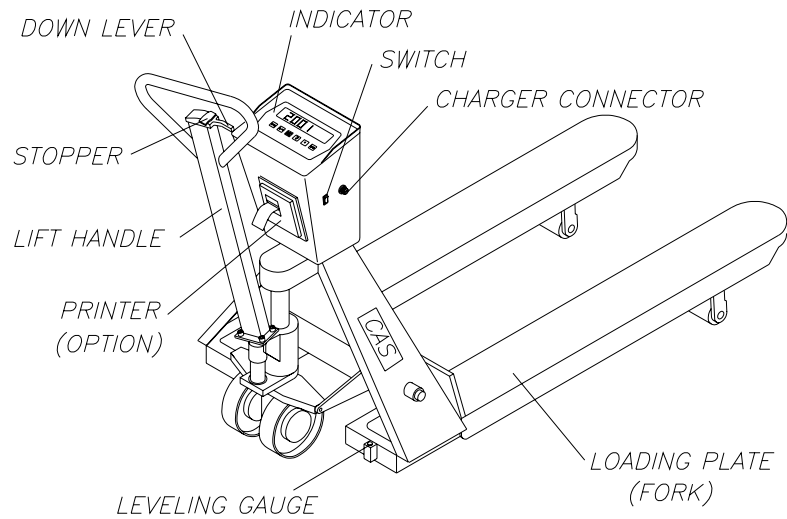

5. HOW TO CHARGE

1. Plug the charger into a AC socket and make sure that the socket's power is within the charger's operating range.
Open the socket's cover located on the right side of indicator and then connect to the connector. (See Fig 1.)
2. Depending on the charging state, the lamp located on the charger will be ON.
3. When the battery is fully charged, the charger lamp will be ON.
4. It takes about 8 hours to fully charge the battery.

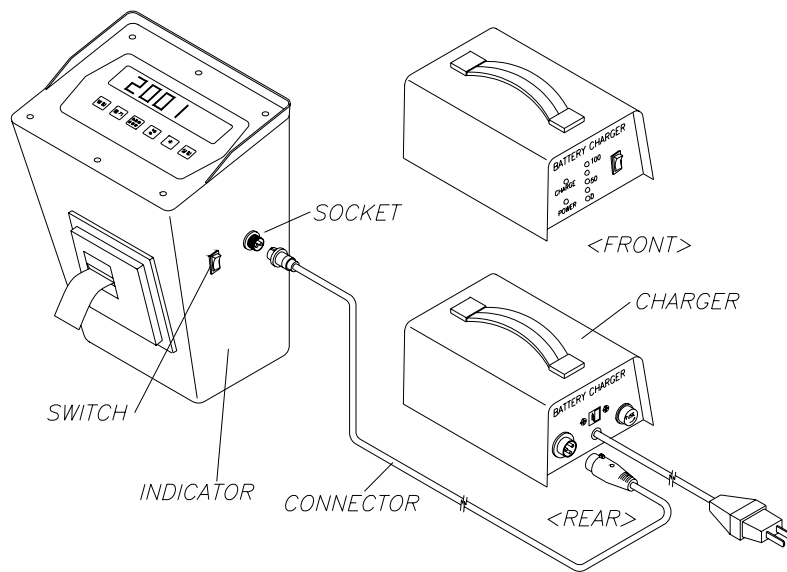

(Fig 1)

HOW TO ASSEMBLE

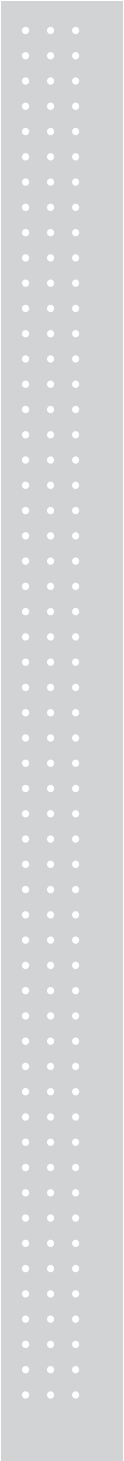
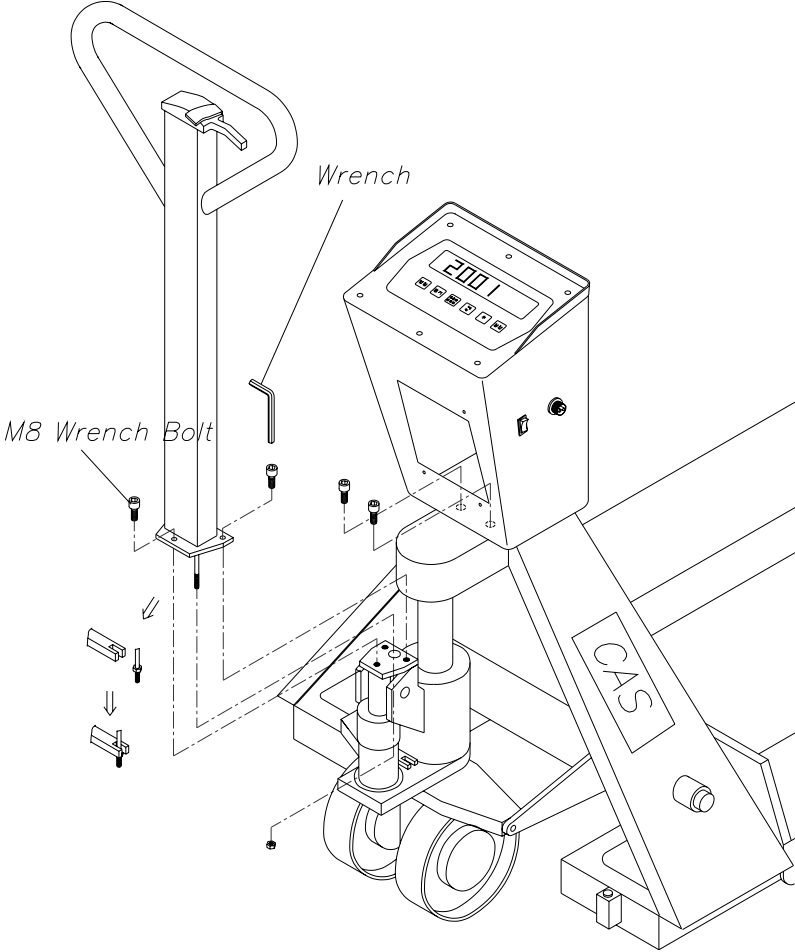

6. FRONT PANEL

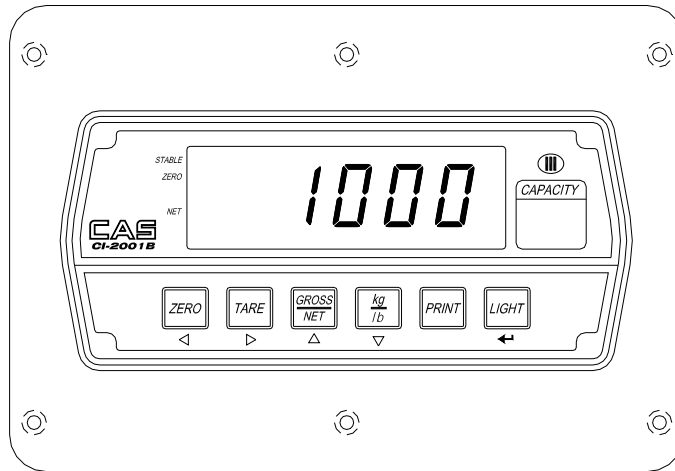

(1) Display lamp

lb lamp : ON when the weight unit is pound [lb]

kg lamp : ON when the weight unit is kilogram [kg]

o lamp : ON when the weight is stable.

ZERO lamp : ON when the current weight is 0 kg(0 lb).

NET lamp : ON when the current weight is NET weight.

TARE lamp : ON when the tare weight is stored.

(2) Keyboard

□ ▲, Key

Available keys instead of numeric keys.

▲ : Change the set value

Increase the first place value to 1

: Change the digit of the set value

Move to the left by 1 place

USAGE : Input the numeral value in TEST, CAL, SET mode.

- ZERO Key : Return the display to 0.
- TARE Key
 - Use container in weighing.
 - Current weight is memorized as tare weight.
 - If you press TARE key in unload condition, Tare setting is released.
- GROSS/NET Key
 - Display gross and net weight by turn.
 - GROSS lamp on - gross weight
 - NET lamp on - net weight
 - In case tare weight is REGISTERED, tare and item's total weight is G weight and only item's weight is N. weight.
- kg/lb Key
 - Toggles between lb and kg units.
- "PRINT" Key
 - 1. PRINT Key
 - Total Print key
 - (by pressing "PRINT" key more than 3 second.)
 - 2. HOLD Key
- "LIGHT" Key
 - In CALIBRATION, TEST, SET mode.
 - : Store current condition and exit.

(3) How to enter SET mode

- Turn on the Power while pressing the "LIGHT" key and SET mode starts.

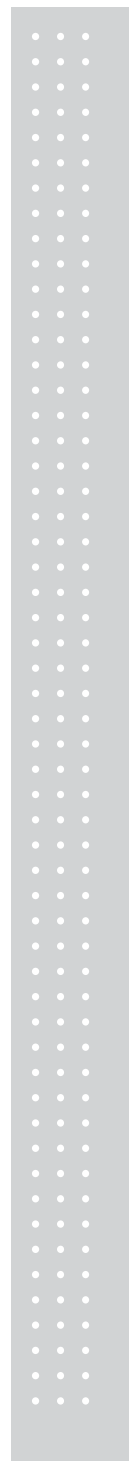



7. SET MODE

(1) HOW TO ENTER

Turn on the power while pressing the "LIGHT" key and SET menu starts.

(2) AVAILABLE KEYS & CONVERTING METHOD

- ▲ KEY : Increase the first place set value to 1
- KEY : Move to the left by 1 place of the set value.
- PRINT KEY : Move to a weight measure mode
- LIGHT KEY : Move into next menu.

(3) SET VALUE CONVERSION MENU (F01 - F14)

- F01 : Select the primary base unit (kg/lb)
- F02 : Designation of serial port usage
- F03 : Automatic zero condition set
- F04 : Digital Filter
- F07 : Weight Back-up (Power-on Actual Weight)
- F08 : "PRINT" Key Usage
- F10 : Device ID
- F11 : Designation of Serial Interface Baud rate
- F12 : Designation of Serial Interface output mode
- F13 : Set HOLD type
- F14 : Select of clock option

Select the primary base unit		
F01	0	primary unit is kg
	1	primary unit is lb

Serial port usage		
F02	0	Not Usage
	1	Connection to serial Printer

Automatic Zero condition set			
F03	0	None Automatic zero	
	1	1 : 0.5 digit	Autozero tracking will automatically bring the display back to "0" when there are small deviations.
	~ 9	. 9 : 4.5 digit	

Digital Filter			
F04	1	1 : Less Vibration	Adjust the set value according to the condition.
	~	.	
	9	9 : Much Vibration	

Select the weight back-up mode		
F07	0	Weight back-up is off (Power on Zero)
	1	Weight back-up is on

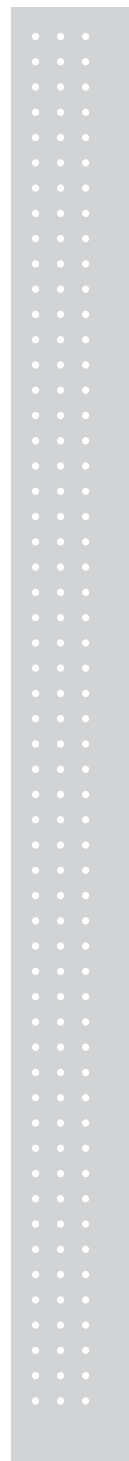

"PRINT" Key Usage		
F08	0	Not used
	1	- Print key (Press "PRINT" key) - Total Print key (by pressing "PRINT" key more than 3 second.)
	2	HOLD Key

Device ID			
F10	00 ~ 99	00: DEVICE ID "00" . . 99 : DEVICE ID "99"	It is used the no. of indicator when system is connected.

Baud Rate		
F11	0	600 bps
	1	1200 bps
	2	2400 bps
	3	4800 bps
	4	9600 bps
	5	19200 bps

Output Mode		
F12	0	No data output
	1	Stream Mode
	2	Transmit only in stable condition
	3	Transmit when data is required Request signal : device ID (F10 : Device ID) (In case F10 : 1, Send Hex Value 01h in Computer)

Set HOLD type		
F13	0	Average hold : Compute the average weight of oscillating weights.
	1	Peak hold : Compute the maximum weight among oscillating weights.

Select Option Clock		
F14	0	Not use Clock
	1	use Clock

Change Date/Time (Ex. 1998/12/11 13:10:01)		
▲ : Increase of no. : Shift of digit LIGHT : Store and move into next menu	LED Display	Meaning
	C1 98	Year : 98
	C2 12	Month : 12
	C3 11	Day : 11
	C4 13	Hour : 13
	C5 10	Minute : 10
	C6 01	Second : 01

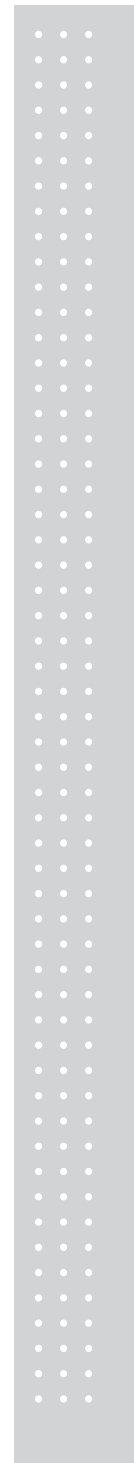

8. Error message & Trouble shooting

Err 01

Reason

The weight is too unstable to initialize the scale.

Trouble shooting

Lay the scale on a flat place and turn on the power.

Err 02

Reason

Load cell connection failure or error in A/D conversion part.

Trouble shooting

Check the load cell connector to see if the polarity of signal is reversed.

Err 06

Reason

Error in printer connection

Trouble shooting

Check with printer connector

If there is no problem with printer and printer connector, please request

A/S to head office.

Err 08

Reason

The ZERO key or TARE key is adjusted not to be operated under the unstable condition.

Trouble shooting

Press Zero or Tare key in stable condition

Err 09

Reason

Current weight deviates from zero range.

Trouble shooting

Press the ZERO key within 10% of the maximum capacity.

Err 10

Reason

Tare weight exceeds the maximum capacity of the scale.

Trouble shooting

Set the tare to be smaller than the maximum capacity.

Otherwise the maximum capacity is reset to be larger than the tare to be set in the calibration menu, and reset the calibration using weight.

Err 13

Reason

The zero range deviates from the set range.

Trouble shooting

Confirm that there is nothing on the weighing platform.

If nothing exist, do calibration in CAL mode.

Over

Reason

The weight on platform is too heavy to be measured.

Trouble shooting

Do not load the item exceeds the maximum tolerance.

If the load cell is damaged, the load cell should be replace.

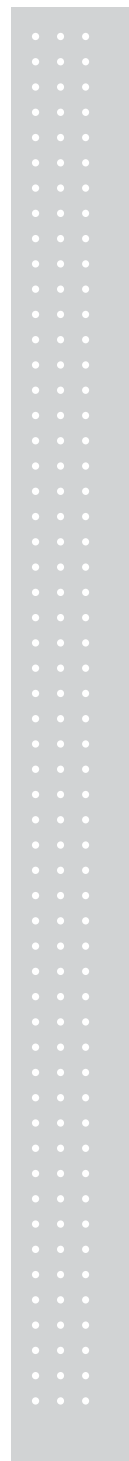

MEMO

