



High Luminous LED



CCD & NIR Camera



Eject Valve

COLOR SORTER

Smart Selection

A color sorter is a product with extensive science. To produce quality grains, the machine should be not only equipped with good quality of a CCD & NIR camera, high speed eject valve, and lamp but also made by a company with cutting-edge technology and highly qualified engineers.



CAS

COLOR SORTER

FEATURES

Sorting Area

It is the place for operating the LED, camera and ejector.



Touch Screen

It can be easily used and offers 20 different languages.

Supply Feed

It helps supply materials accurately.

Sorted sample



High luminant 3Color LED, Bi-chromatic Camera & NIR

with the highest resolution & brightness to detect and then reject the smallest defects even on the invisible properties, the ISORT series will always offer customers higher profitability and satisfaction.

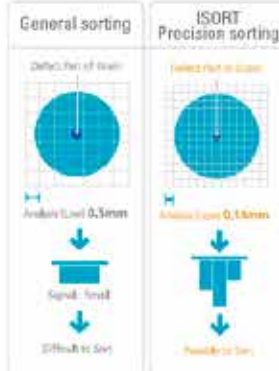
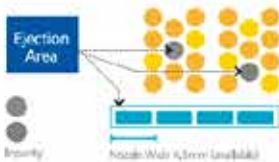

Outlet for Quality & Defective Materials

A passage to release quality and defective materials

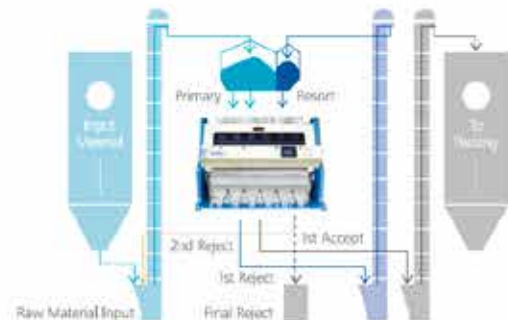

| Smart Selection

KEY TECHNOLOGY

It took ISORT 20 years to become a leader in sorting machines. ISORT products are manufactured based on 20-years of know-how which developed along with a history of producing different kinds of sorters: from analog to digital types, and from sensor types to NIR.

High Luminant LED

All materials are perfectly lightened by installing LED which creates three colors.



Multiple Chute

It induces the flow of materials in the best manner possible by applying the most suitable chute.

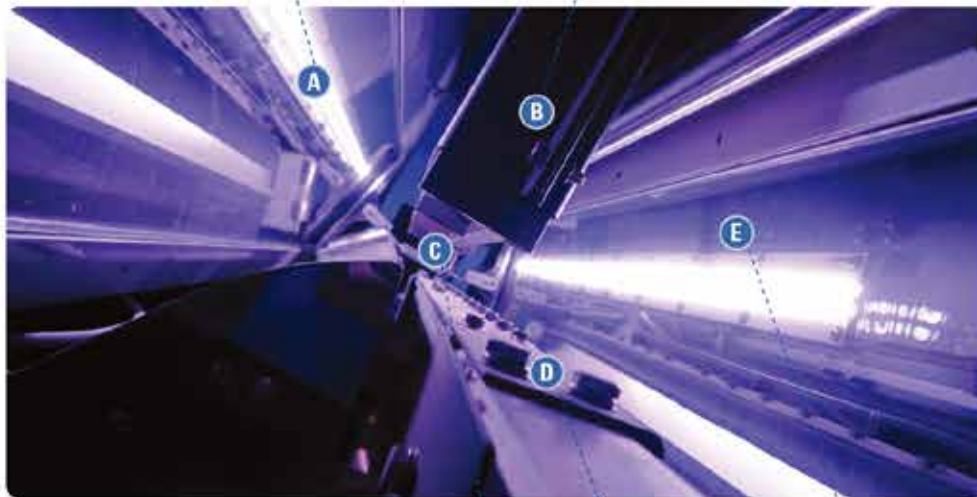

Cleaning System

To maintain the best production environment, an automatic cleaning system is included, so even tiny particles of dust cannot be allowed to enter the machine.

Eject Valve

It can sort out all defective products through the installation of an eject valve that moves over 1,000 times per second.



CCD & NIR Camera

All materials can be selected accurately by equipping the machine with a CCD camera, and an NIR camera, if necessary.



COLOR SORTER | Smart Selection

SPECIFICATIONS

Rice Color Sorter

Model	3GR2	3GR3	3GR4	3GR5	3GR6
Dimension (WxLxH)	1000x1830 x1890	1700x1830 x1890	2000x1830 x1890	2100x1830 x1890	2500x1830 x1890
Power	2 kW/Hr	3 kW/Hr	4 kW/Hr	5 kW/Hr	6 kW/Hr
	220-440V(50-60Hz)				
Scan camera	CCD Camera / NIR Camera(option)				
Camera quantity	4	6	8	10	12
Vision lamp	LED				
Capacity(Ton/Hr)	2	2-5	3-7	10	12
Compressor (Required)(Hp)	15	20	30	30	40

Multiple Color Sorter

Model	3GM2	3GM3	3GM4	3GM5	3GM6
Dimension (WxLxH)	1000x1830 x1890	1700x1830 x1890	2000x1830 x1890	2100x1830 x1890	2500x1830 x1890
Power	2 kW/Hr	3 kW/Hr	4 kW/Hr	5 kW/Hr	6 kW/Hr
	220-440V(50-60Hz)				
Scan camera	CCD Camera / NIR Camera(option)				
Camera quantity	4	6	8	10	12
Vision lamp	LED				
Capacity(Ton/Hr)	2	2-5	3-7	4-8	5-10
Compressor (Required)(Hp)	15	20	30	30	40

FEATURES

All places which need to sort quality goods!

- Grain processing and packing companies
- Coffee processing companies
- Dried fish processing companies
- Plastic raw material manufacturers
- Dried vegetable processing, and Large-size farms and food processing companies
- Sea salt processing companies

DIMENSION

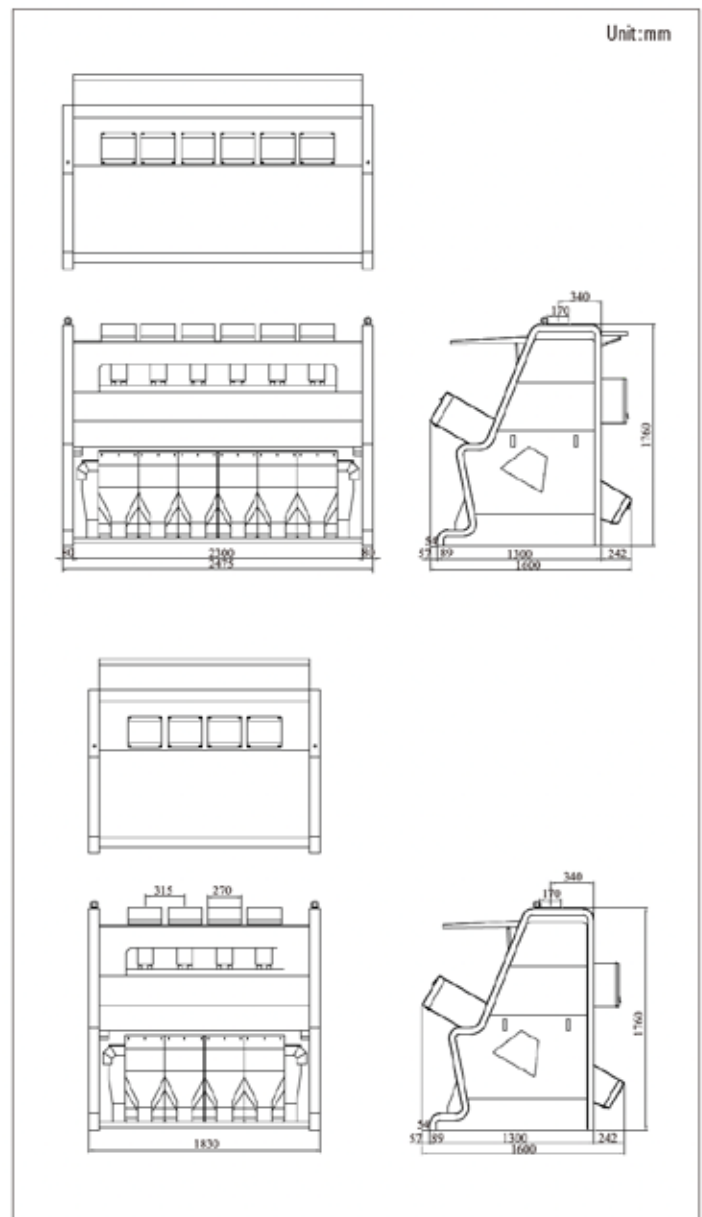

CAS

1315, YANGJAE-DAERO,
GANGDONG-GU, SEOUL, KOREA
TEL_ 82 2 2225 3500
FAX_ 82 2 475 4668

<http://www.globalcas.com>

Specifications are subject to change for improvement without prior notice.