

CMB-20

CAS BANDSEALER

It is a machine that bonded in a continuous heating method. the all kinds of vinyl by heat. It is appropriate when packing some material that is easy to pour such as Organic fertilizer, grain, chemical resin.



CMB-20 | CAS BANDSEALER

FEATURES

- Easy for operation
- Possible to adjust the height of the band sealer body
- It is possible to adjust the working speed
- It is available to adhere strongly safe in films of any kind using SEALING BAND
- It can be bonded film securely even with pressure roller apparatus if dirt is attached
- It is possible to bond to be able to adjust the state of the optimum for pressure of the SEAL BAR according to the material and thickness
- It is available for adhesion gazette bag or retort pouch
- Hot Printer installed, It is possible to reduce the step to be able to print at the same time in bonding process such as the expiration date and Date of Manufacture
- Used organic fertilizer, feed, medicine, grain (rice, soybean), chemical resin

SPECIFICATIONS

Model	CMB-20
Power	3 phase 200V ~ 440V, 50Hz/60Hz, 4Kw
Product Size(mm)	2,000(W) x 920(H) x 1,860(D)
Adhesion line area(mm)	10
Temperature control	0°C ~ 300°C
Adhesion Heater	220V 400W 8EA
Adhesion Speed	0~18m/min
Sealing Band	35 X 2,900(Teflon)
FRAME materail	Steel & Stainless
Cooling system	liquid-cooled 20L(Cooling Machine)
Options	Printer installation - Solid ink
	Power 3 Phase 220V (Motor, inverter change)
	FRAME : SUS
	possible to change the opposite of product hole(CMB-20L)

제품크기

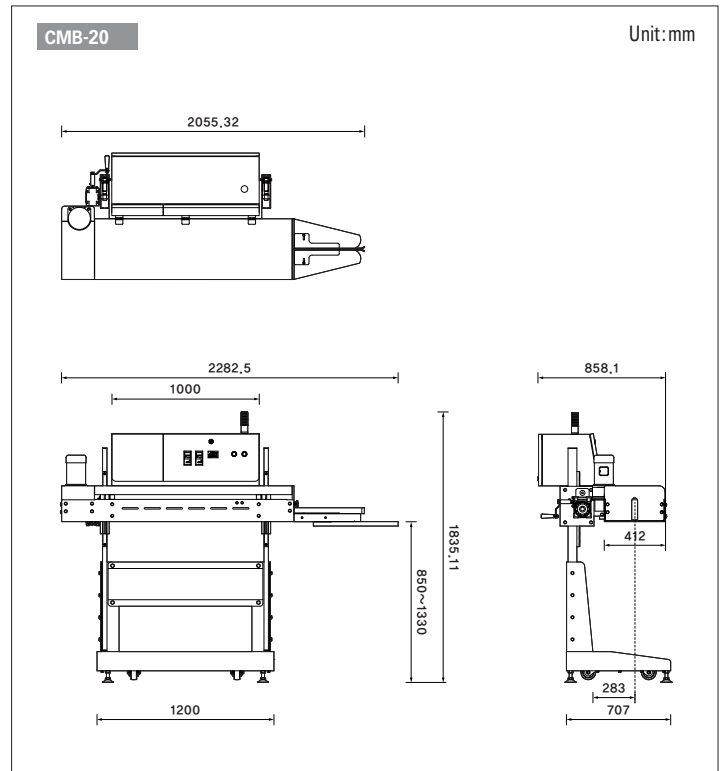

CAS

#1315 YANGJAE-DAERO,
GANGDONG-GU, SEOUL, KOREA

TEL_ 82 2 2225 3500

FAX_ 82 2 475 4668

<http://www.globalcas.com>

Specifications are subject to change for improvement without prior notice.