

RETAIL WEIGHING SOLUTION™

CL5500 Cart Scale

Cart Scale Series

CL5500-CART SCALE is a mobile scale that can perform weighing and label printing simultaneous with outstanding mobility at the site of warehousing and shipping of products. With outstanding efficiency, it is excellent in simplifying the process of the logistics at sites of warehousing and shipping of products, thereby reducing both time and cost.



Realization of CL5500 Function



Diverse range of options



Powerful network system



Realization of CL5500 Function

Ease of movement

Powerful network system

Scan with your smartphone
to find more products



CAS
www.globalcas.com

CL5500

Cart Scale Series



Perfect Realization Of CL5500 Function

- Realization of beef history management by utilizing scanner
- High speed printer
- Clear display
- Powerful network system (basic application of wired LAN)
- Efficient data management using dedicated program



Structure That Is Optimal For The Logistics Environment

- Reduction in work time through concurrent execution of weighing, outputting and moving
- Attachment of urethane wheel with outstanding durability
- Battery format for easy mobility



Feature

- Easy data management using powerful network
- Fortification of durability and convenient mobility with the attachment of polyurethane wheels
- Quick management of products by using scanner (support management of the history of beef)
- Supports a diverse range of label printing formats

Application

- Meat processing & distribution center
- Management of the weight of products being warehoused & shipped out (product inspection)
- Mobile weighing of cargo in courier and distribution warehouses
- Inspection management of industrial products



Option

- Wireless LAN Card (WIFI)
- Wireless barcode scanner



Specification

MODEL	CL5500-CART SCALE	
Maximum indication (kg)	60	150
Value of each scale (kg)	10/20	20/50
Degradability	1/3,000(Dual interval)	
Display type	Graphic LCD(202x32dot) + Numeric LCD(4/5/6/6)	
Printing Speed (mm/sec)	100	
Operating temperature range(°C)	-10 ~ +40	
Power supply	AC100~240V, 50/60Hz, PB battery	
Duration of use/charging	8hr(issuance of 300sheets of label)/4hr	
Size of cargo plate (mm)	420(W) x 510(D)	
Product Dimensions (mm)	940(W) x 420(D) x 1295(H)	
Product Weight (kg)	83	

Dimension

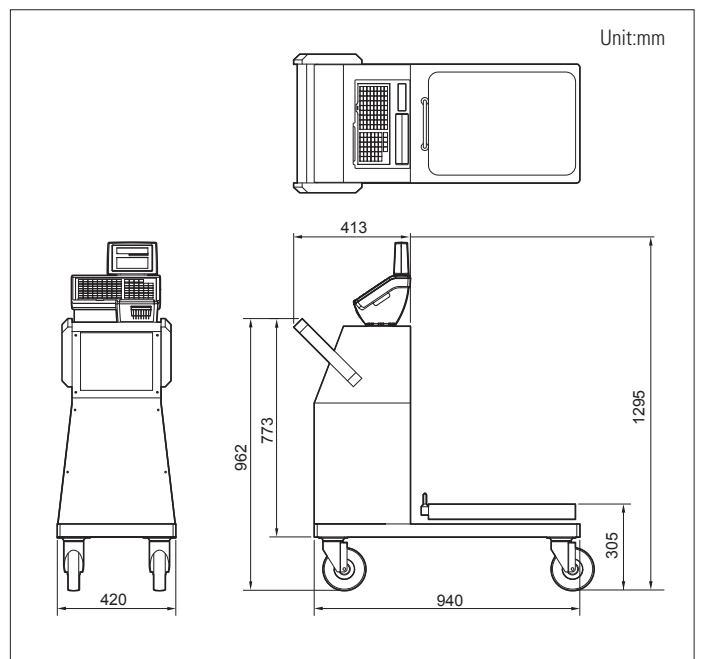

CAS BLDG., 1315, YANGJAE-DAERO,
GANGDONG-GU, SEOUL, KOREA
TEL_ 82 2 2225 3500
FAX_ 82 2 475 4668

Specifications are subject to change without notice improvement



<http://www.globalcas.com>

