

INDUSTRIAL WEIGHING SOLUTION™

# CASTON-II SERIES

## Crane Scale

- Available in 500×0.2 kg, 1000×0.5 kg, 2000×1 kg, 3000×2 kg or 5000×2 kg Capacities
- Easy-to-Read 1.2" LED Display
- Wireless Remote Control Standard
- Battery Operated



Scan with your smartphone to find more products

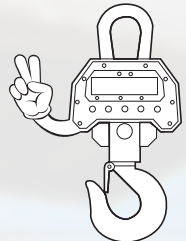

**CAS**

www.globalcas.com

# CASTON-II SERIES

## Crane Scale



### FEATURES

- Battery Operated with Low Battery Indication
- Rechargeable Battery Pack
- Spare Battery Pack and Charger Included as Standard
- Remote Control Included as Standard
- On, Off, Zero, Tare, and Hold(Manual or Automatic), Functions
- Easy-to-Read 1.2" LED Display
- Auto Span Adjustment
- Auto Zero Tracking

### SPECIFICATIONS

Model	0.5 THB	1 THB	2 THB	3 THB	5 THB
Weighing Capacity	500×0.2kg	1000×0.5kg	2000×1kg	3000×2kg	5000×2kg
Maximum Tare	Full Tare				
Display Type	LED(1.2 inch)				
Operating Power	DC6V				
Power Source	AC 110/120/220/24V, 50/60Hz				
Display Designators	Zero, Tare, Hold, Batt.				
Power Consumption	1W				
Operating Temperature	-10°C ~ +40°C				
Product Weight	17kg				

### DIMENSIONS

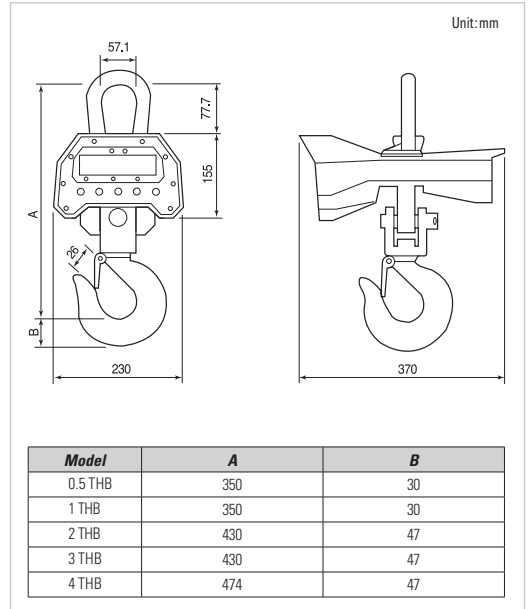

▲ Display & Key board



Battery Pack Installation ▶