

Caston I

Crane Scale

Battery operated/Low battery indicated
Standard AC adapter & Rechargeable battery
LED/LCD type
Water proof(IP 65)
On/Off, Zero, Tare and Hold
(Manual or Automatic) functions



CAS



CASTON-I Crane Scale

FEATURES

- Battery operated/Low battery indicated
- Standard AC adapter & Rechargeable battery
- LED/LCD type
- Water proof(IP 65)
- On/Off, Zero, Tare and Hold (Manual or Automatic) functions
- Options:TW-150(Tele-weigh display), Wireless remote control standard
- Display Lamp:
 - LED(Power, Charge, Low bat, Zero, Net, Hold)
 - LCD(Power, Charge, bat, Stable, Zero, Net, Hold)

SPECIFICATIONS

MODEL	0.1THA	0.2THA	0.3THA	0.5THA	1THA	2THA
Max.Capacity	100kg	200kg	300kg	500kg	1000kg	2000kg
Repeatability	0.05kg	0.01kg	0.2kg	0.5kg	1kg	
Maximum Tare	Full Tare					
Display Digits	LED(5digit 0.8inch)/LCD(5digit 0.9inch)					
Operating Temperature	-10 ~ +40					
Function	Standard(ON/OFF, ZERO, TARE, HOLD) Option(Remote Control)					
Operating Power	DC 12V					
Power Source	AC 110/120/220/240V, 50/60Hz					
Power Consumption	LED(1.2W)/LCD(0.5W)					
Dimensions(mm)	258(W)x440(D)x133(H)					
Product Weight	5.2kg	5.3kg			5.5kg	



Remote Control

SPECIFICATIONS

Available Distance	6m~10m
Available Angle	60°
Power	3V

DIMENSIONS

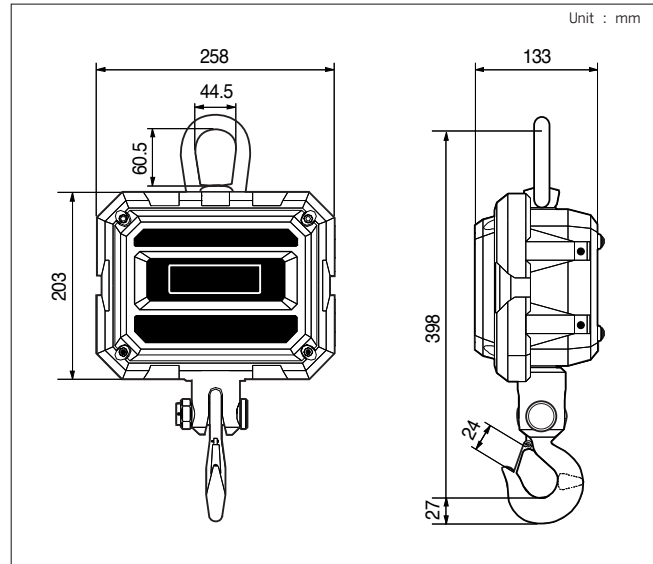

DISPLAY



LED TYPE



LCD TYPE

KEY FUNCTIONS



BATTERY USAGE

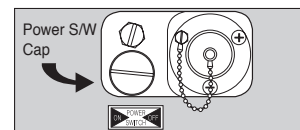
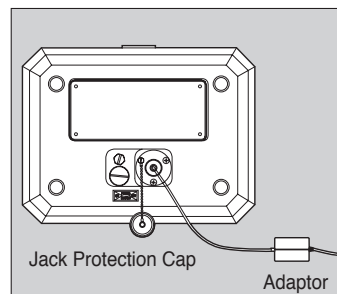

BATTERY SPECIFICATIONS

- ▶ NOMINAL CAPACITY : 2000mA
- ▶ NOMINAL VOLTAGE : 1.2V (1 Cell)
- ▶ NOMINAL SIZE : C Type

CAS

CAS BLDG., # 440-1, SUNGNAE-DONG,
GANGDONG-GU, SEOUL, KOREA
TEL : 82-2-2225-3500
FAX : 82-2-475-4668
<http://www.cas.co.kr>

Specifications are subject to change for improvement without prior notice.