

INDUSTRIAL WEIGHING SOLUTION™

CASTON THE

Crane Scale

CASTON THE is ideal for heavy duty application in rough industrial environment. Convenient, safe and high accuracy with a high-visibility LED display, easy install and recharging of battery pack and wireless remote control.



Rechargeable Battery

Remote Control

LED Display

Frontal Shadow-type Cover Design

Frontal Shadow-type Cover



Remote Control



LED Display



Red LED

Green LED

Scan with your smartphone
to find more products



CAS
www.globalcas.com

CASTON THE

Crane Scale



FEATURE

Sun Visor-type Cover Design

- Sun Visor guarantees the legibility of the display while outdoors.

3 Optional Remote Controller

- Pocket type, Normal type, Display type (Option)



- In 20m distance control



High-Visibility LED Display



Red LED

Green LED

Rechargeable Battery

- 38 hours continuous use

APPLICATION

- Steel
- Ship
- Production
- Food
- Farm

SPECIFICATIONS

Model	CASTON THE
Display	5 Digital, 30mm LED/LCD
Setting Time	5-8s
Control Distance	≤20m
Battery	Rechargeable 6V/4AH
Tare Range	100% Full Span
Over Load Warning	110% Full Span
Safe Overload	125% Full Span
Limit Load	400% Full Span
Work Temperature	-10°C ~ +40°C

DIMENSION

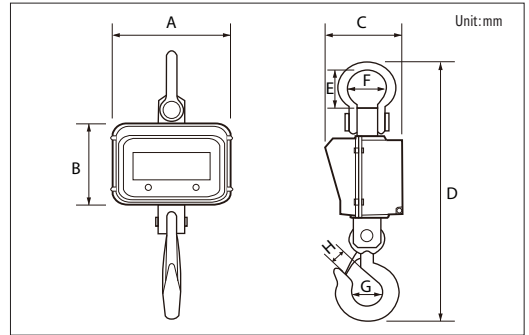

Model	Span kg	Division kg	A	B	C	D	E	F	G	H	Weight kg
THE-2T	2000	1	210	170	205	530	76	63	46	40	13.5
THE-3T	3000	1	210	170	205	530	76	63	46	40	13.5
THE-5T	5000	2	210	170	205	620	88	78	60	52	18.5
THE-10T	10000	5	210	170	205	660	114	92	71	55	30
THE-15T	15000	5	210	170	205	740	128	97	80	68	36.5

