

BW-2

Battery Operated Bench Platform Scales

- NEMA 4X / IP65 indicator enclosure
- 304 stainless steel construction
- Auto / Manual back light display
- WATCHDOG circuitry
& Weight back-up



CAS



BW-2 Battery Operated Bench Platform Scales

FEATURES

- NEMA 4X / IP65 indicator enclosure
- 304 stainless steel construction
- AC operation & Optional battery operated
- Auto / Manual back light display
- WATCHDOG circuitry & Weight back-up
- Count function
- Check weighing function (Low/Ok/High)
- RS 232C interface / Serial printer function
- Change unit (lb, kg, oz) or HOLD function

SPECIFICATIONS

Model	BW II-6	BW II-15	BW II-30	BW II-60	BW II-150
Max. capacity	6kg	15kg	30kg	60kg	150kg
Mini. division	2g	5g	10g	20g	50g
Function	Standard	ON/OFF, ZERO, TARE, HOLD, COUNT, HIGH/LOW Comparing			
Display Digits	5 Digit LCD (H=23.5mm)				
External Resolution	1/3,000				
Display Annunciators	HI, OK, LO, -, BAT, PCS				
Load cell permission voltage	5V DC				
Temperature range	-10°C ~ +40°C				
Max. Tare range	Max. Capacity				
Zero compensation range	±2% of Max. Capacity				
Initial zero range	±10% of Max. Capacity				
Power	AC220V/50Hz, 60Hz AC110V/50Hz, 60Hz				
Consumption	Approx.12W				

OPTIONS

- Rechargeable Lead-Acid battery (DC 6V, 10AH) & Recharge circuit board
- RS 485 / 422 communication
- External contact output (Zero, Low, Ok, High)

DIMENSIONS

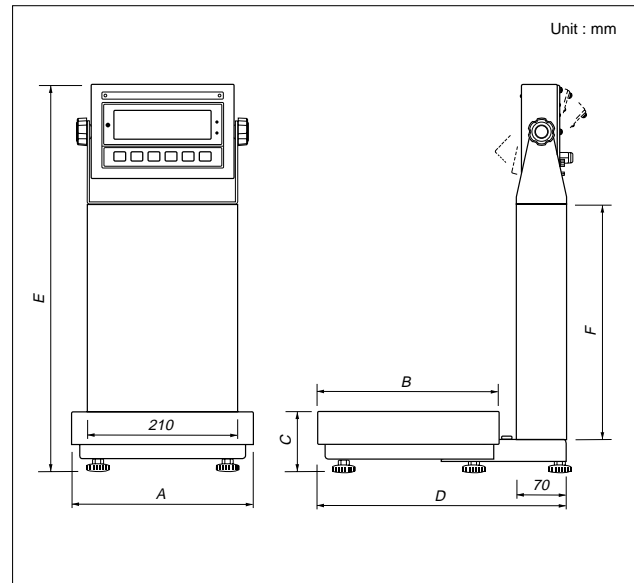

Unit : mm

Max. capacity	A	B	C	D	E	F
6, 15, 30kg	254	254	82	347	538	325
15, 30kg	305	305	82	405	538	325
15, 30kg	305	406	82	500	538	325
60, 150kg	457	457	143	547	722	500
60, 150kg	457	610	143	698	722	500

CAS

CAS BLDG., # 440-1, SUNGNAE-DONG,
GANGDONG-GU, SEOUL, KOREA
TEL : 82-2-2225-3500
FAX : 82-2-475-4668
<http://www.cas.co.kr>

Specifications are subject to change for improvement without prior notice.