

Simple Weighing Scale

SWN series



◀ SWN-SC

Simple Weighing Scale SWN

Desktop simple weighing scale SWN series is optimal for use in various environments from restaurant kitchens & markets, small marts to production factories.

Also, Large & bright display makes it easy to check the weight value.

Weight data can be transmitted to a PC or external device using RS-232C, USB or BLE as an option.



▶ SWN-CC

▶ SWN-CE



Large & bright display



Long battery operation



Fast operation and high accuracy



Convenient to carry

CAS

FEATURES

• Large & bright display

6 digits LED/LCD display offers high visibility in any lighting condition. Also, dual display design(optional) increases productivity as two operators can work at the same time.

- LCD Display (Character Height : 29mm with Backlight)



- LED Display (Character Height : 17.3mm)



• Long battery operation

- LCD : 1.5V D size 4 dry battery x 4ea, Alkaline – 1000hours / Mn – 500hours

- LED : Rechargeable battery : 70hours

* when using continuously with the backlight off of LCD display

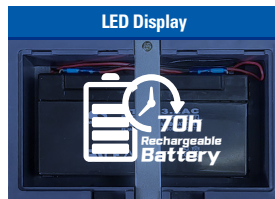

• Fast & accurate weighing

SWN is equipped with CAS One-chip which guarantees fast and accurate weighing performance.



• Convenient to carry

Light-weight and portable design of SWN allows easy carrying of the scale with either one or two hands.



• Various Communication Interface (optional)

- RS-232C, USB (Available simultaneously)

Power supply and communication support via USB, making it easy to connect with external devices such as PC and POS

- BLE wireless communication

SPECIFICATIONS

Model	SWN-SC / SWN-CC (LCD)				SWN-SE / SWN-CE (LED)			
Capacity (kg)	1.5/3	3/6	6/15	15/30	1.5/3	3/6	6/15	15/30
Readability (g)	0.5/1	1/2	2/5	5/10	0.5/1	1/2	2/5	5/10
Resolution	Dual 1/3,000							
Display	6digit LCD+BL (Height : 29mm)				6digit LED (Height : 17.3mm)			
Symbol	Stable, Zero, Tare, Low battery, HI/LO/OK(SWN-CC/CE)							
Key	SWN-SC/SE : Power, Zero, Tare, Hold SWN-CC/CE : Power, Zero, Tare, Mode							
Function	SWN-SC/SE : General Weighing, Hold, Auto power off SWN-CC/CE : General Weighing, Counting/Check-weighing, Auto power off							
Power	1.5V D size dry battery x 4ea Optional : 9VDC /300mA Adaptor				6VDC 3.2Ah Pb rechargeable battery 12VDC / 1.25A Adaptor			
Battery life	Alkaline : 1,000hours Mn : 500hours				70hours			
	When Continuously Using with single display in backlight off							
Communication	Optional : RS-232C, USB or BLE (Available simultaneously)							
Product size (mm)	256 (W) x 285 (D) x 123 (H)							
Platter size (mm)	239(W)x192(D)							
Product weight (kg)	2.7							
Option	Rear Display, RS-232C, USB or BLE Stainless steel Tray, 9VDC/300mA Adaptor(SWN-SC/CC)							

DIMENSIONS

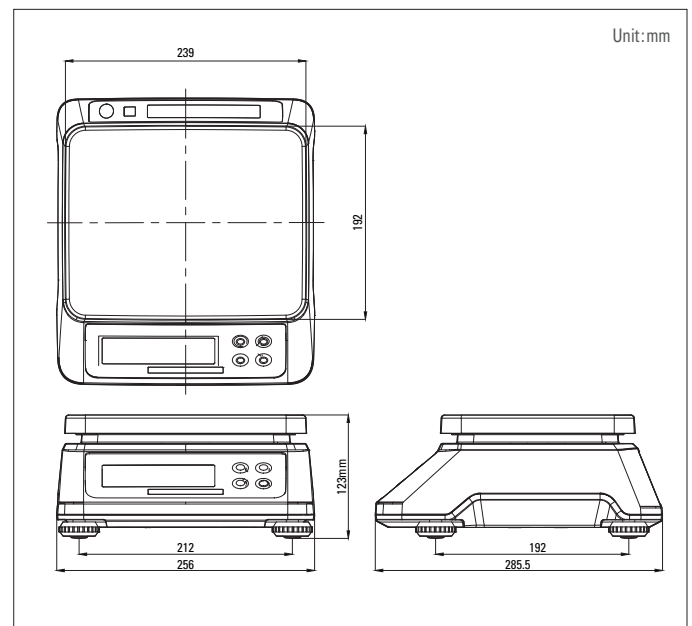

OPTIONS

- Communication : RS-232C, USB or BLE (Available simultaneously; Factory option)

- Stainless Steel Tray, Rear Display, 9VDC/300mA Adaptor(LCD)



Ver.1.1_40214202



CAS Global Homepage

CAS Co., Ltd

Headquarters : 262, Geurugogae-ro, Gwangjeok-myeon, Yangju-si, Gyeonggi-do, Korea

Seoul Office : CAS Building, 1315, Yangjae-daero, Gangdong-gu, Seoul, Korea

TEL : 82 2 2225 3500 FAX : 82 2 475 4668

www.globalcas.com



* Specifications are subject to change without notice improvement.