

TOTAL WEIGHING SOLUTION™

HFS-CPK2

Bulk Bag Packing Scale

CAS' modular bulk bag scale is perfectly designed to bag precise weight of materials, from hard to flow, equipped with CAS' load cells to get the accurate weight. The scale is simply easy to install because the scale comes with modules: upper hopper, shutter and spring, and each module can be purchased separately.



Simple structural design

Modular bulk Bag Scale

Four caster wheels for mobility



Simple structural design

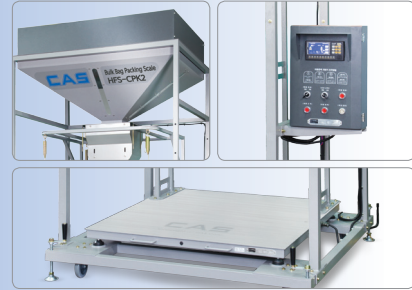

Modular bulk Bag Scale



Four caster wheels for mobility

Scan with your smartphone
to find more products

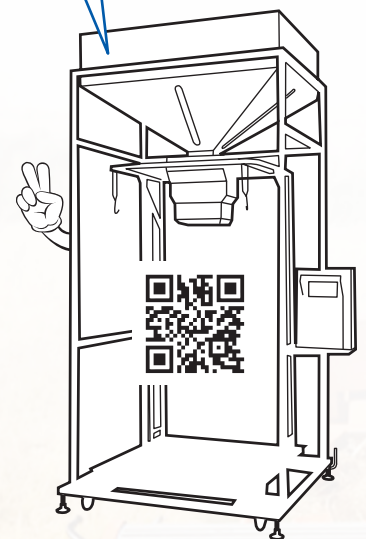

CAS
www.globalcas.com

HFS-CPK2

Bulk Bag Packing Scale



Feature



Bulk storage container (Optional)

Easy-to-use clear display

Stainless steel platform scale for accurate weighing

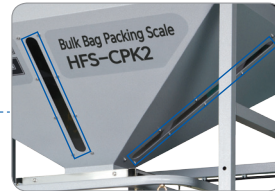

Sight glasses for view of contents



Length adjustable slide gate

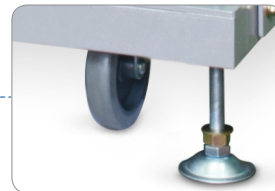

Portable with four caster wheels

Specification

MODEL	HFS-CPK
Capacity	2,000kg
Readability	1kg
Dimensions	1,550(W) x 1,460(D) x 3,000(H)mm
Power	AC 220V

Dimension

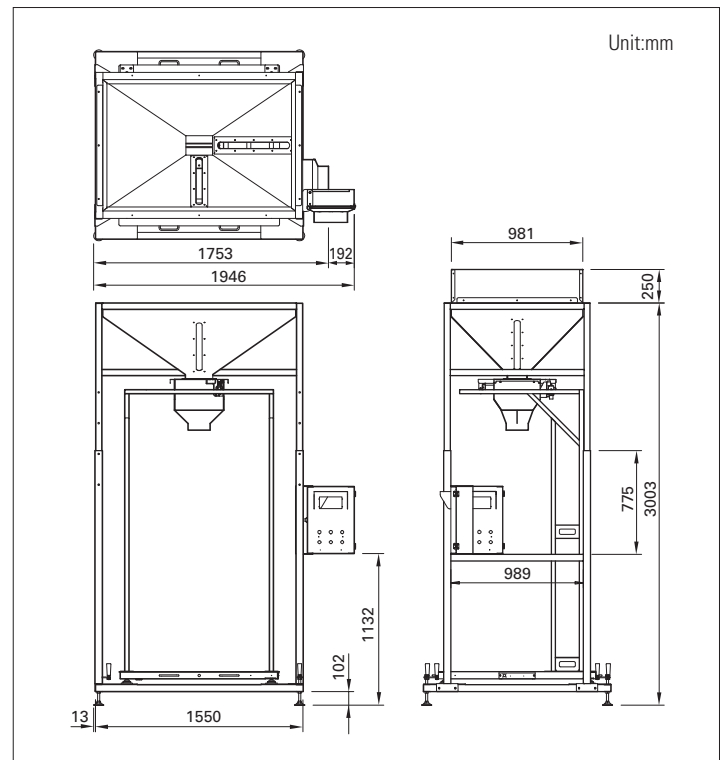

Modules

Upper Hopper



Spring



Shutter

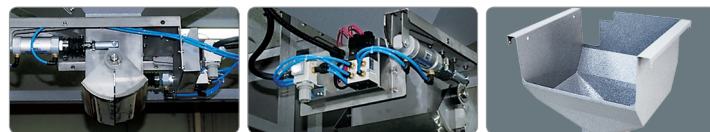

Option

- Bulk storage container