

## Crane Scale

# HD PLUS SERIES



## Crane Scale HD<sup>PLUS</sup>

HD<sup>PLUS</sup> series is high accuracy, compact crane scale for low capacity applications such as livestock industry and agriculture, fisheries with High-visibility LED display and lightweight and Robust enclosure.

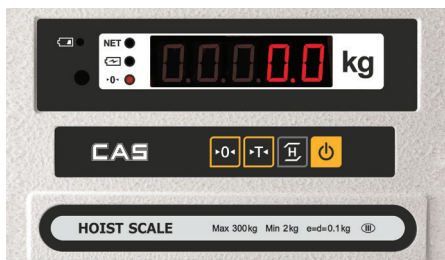

High-visibility LED display



Lightweight & Robust enclosure



Swivel hook

## FEATURES

### 1. High-visibility LED display

User can easily see the weight value in any distance via high-visibility LED display.



### 2. Lightweight & Robust enclosure

Via lightweight and robust enclosure, suitable for low capacity applications such as livestock industry and agriculture, fisheries etc.



### 3. Swivel Hook

HD PLUS series offers convenient and safe weighing and accuracy through swivel hook.



4. Key function : Power On/off, Zero, Tare, Hold

5. Auto power off / Sleep mode / Hold function

6. Swivel hook (360° movement of working load)

## SPECIFICATIONS

Model	HD PLUS Series			
Max. Capacity (kg)	100	200	300	500
Division (g)	50	100	100	200
Display	LED (0.8 inch)			
Status Lamp	Zero, Tare, Charging, Low Battery			
Operating Temperature	-10°C ~ +40°C			
Power	DC 6V Rechargeable battery/AC Adaptor			
Battery operating time	Min : Approx. 32hours(when using Bluetooth or Zigbee) Max : Approx.112hours(in Sleep mode)			
Battery charging time	Approx. 7 hour			
Product size(mm)	266(W)x 116(D) x476(H)			
Product weight	Approx. 6.5 kg			

## DIMENSIONS

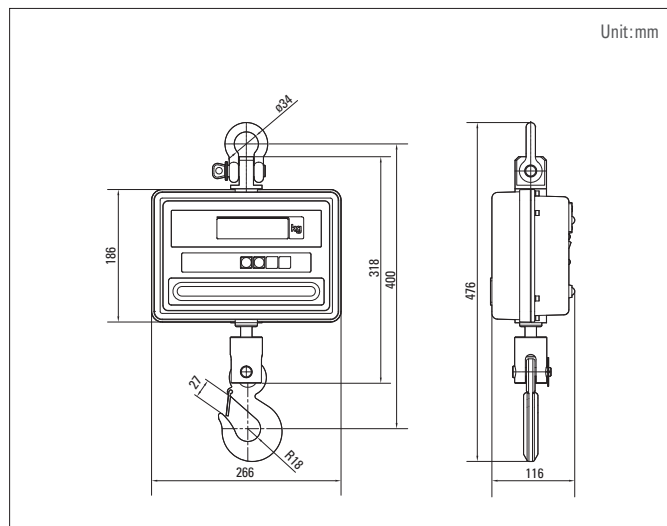

## OPTIONS

- Double hook
- Remote Controller
- Bluetooth Communication
- Zigbee Communication
- TWN-B or Z (Selectable between Bluetooth and Zigbee type)

