

HBS

Stainless Steel Load Cell

- All stainless steel construction
- Available in 20 kgf up to 200 kgf capacity
- Hermetically sealed



APPLICATION

- Platform scales
- Tank & Hopper scales
- Conveyor scales
- Process control

CAS

HBS Stainless Steel Load Cell

DIMENSIONS

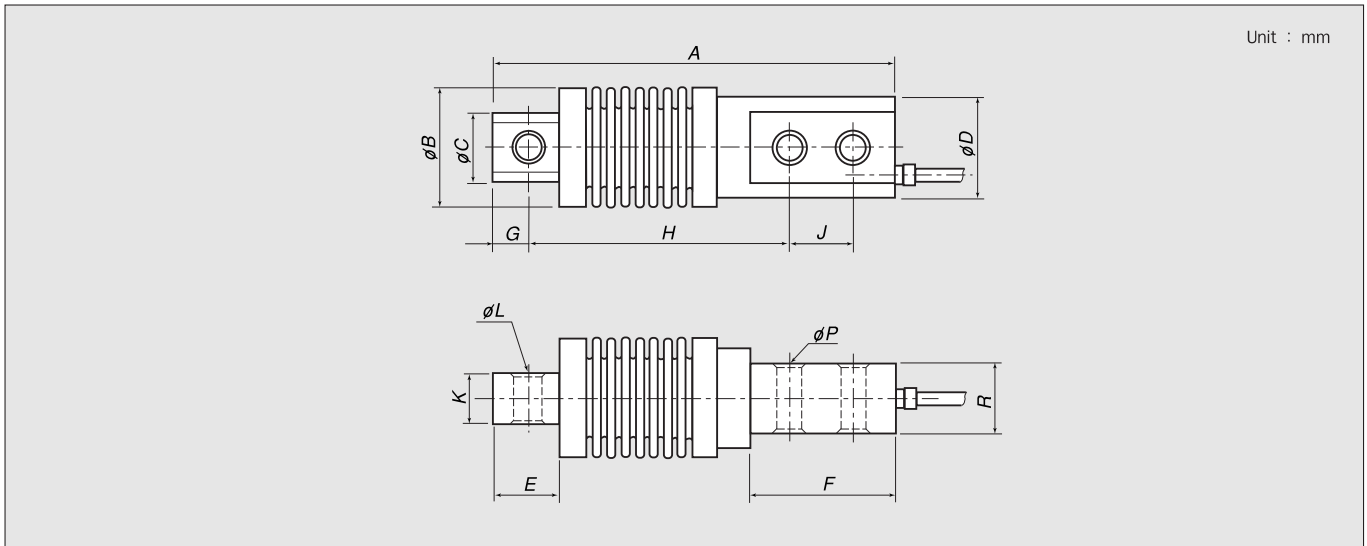

CAPACITY	A	∅ B	∅ C	∅ D	E	F	G	H	J	K	∅ L	∅ P	R
20 kgf - 200 kgf	120	40	23	31.75	20	42	10	82	18	20	8.2	8.2	20

SPECIFICATIONS

Rated Load (R.L.)	20 kgf, 50 kgf, 100 kgf, 200 kgf	
Rated Output (R.O.)	2.0 mV/V ± 0.25 %	
Accuracy Class	D 3	C 3
Combined Error	< 0.03 % R.O.	< 0.02 % R.O.
Repeatability	< 0.01 % R.O.	< 0.01 % R.O.
Creep (for 30min) / -10°C to +40°C	< 0.03 % R.O.	< 0.017 % R.O.
Temperature Effect on Zero Value / 10 °C	< 0.028 % R.O.	< 0.014 % R.O.
Temperature Effect on Output Value / 10 °C	< 0.015 % R.O.	< 0.011 % R.O.
Recommended Excitation	DC 10 V	
Maximum Excitation	DC 15 V	
Zero Balance	± 1 % R.O.	
Input Resistance	400 ± 20 Ω	
Output Resistance	350 ± 3.5 Ω	
Insulation Resistance	> 2000 MΩ	
Cable	3 m, 4 conductor with shield	
Compensated Temperature Range	- 10°C to +40°C	
Operating Temperature Range	- 45°C to +65°C	
Safe Overload	150 % Rated Load	
Protection	IP 67	

ORDERING INFORMATION

CAPACITY	MODEL NO.
20 kgf	HBS - 20 L
50 kgf	HBS - 50 L
100 kgf	HBS - 100 L
200 kgf	HBS - 200 L

CABLE COLOR CODE

Red	+ Excitation
White	- Excitation
Green	+ Signal
Blue	- Signal
Black	Shield

CAS

CAS BLDG., # 440-1, SUNGNAE-DONG,
GANGDONG-GU, SEOUL, KOREA
TEL : 82 - 2 - 2225 - 3500
FAX : 82 - 2 - 475 - 4668
<http://www.cas.co.kr>

Specifications are subject to change for improvement without prior notice.

2000.5