

FS-500

Automatic Combination Weigher

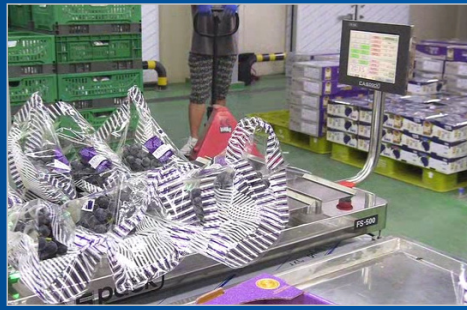

Specifications

Model	FS-500
Capacity	5kg/Tray
Qty of tray	12ea
Range	5 ~ 5,000g
Accuracy	±0.5g
Display	8" Touch screen
Performance	30times/min.
Power	AC 100-240V, 50/60Hz
Operating Temperature	-10 ~ +40°C
Weight of product	30kg
Language	Korean/English/Chinese/Japanese/Turkish/Russian etc.
Qty of Registration	64ea
Ability	Set of Upper/Lower limit Automatic zero adjustment
Option	Total count, SD memory card etc.
Tray Size (mm)	115(W) x 170(D)
Dimensions (mm)	1126(W) x 455(D) x 503(H)

Dimensions

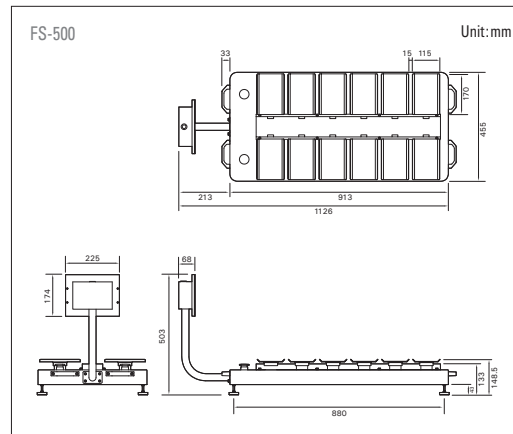

Features

- 8" Touch screen
- Easy cleaning by detachable tray
- Easy moving and installing by table type
- LED lamp for Checking error

FS-500

Automatic Combination Weigher

FS-500 is Table-top type for easy moving and designed compactly. Anyone uses it for work easily and accurately. It is suitable for farm and agriculture, fisheries fields with CAS innovative technology.



Mix Weighing System

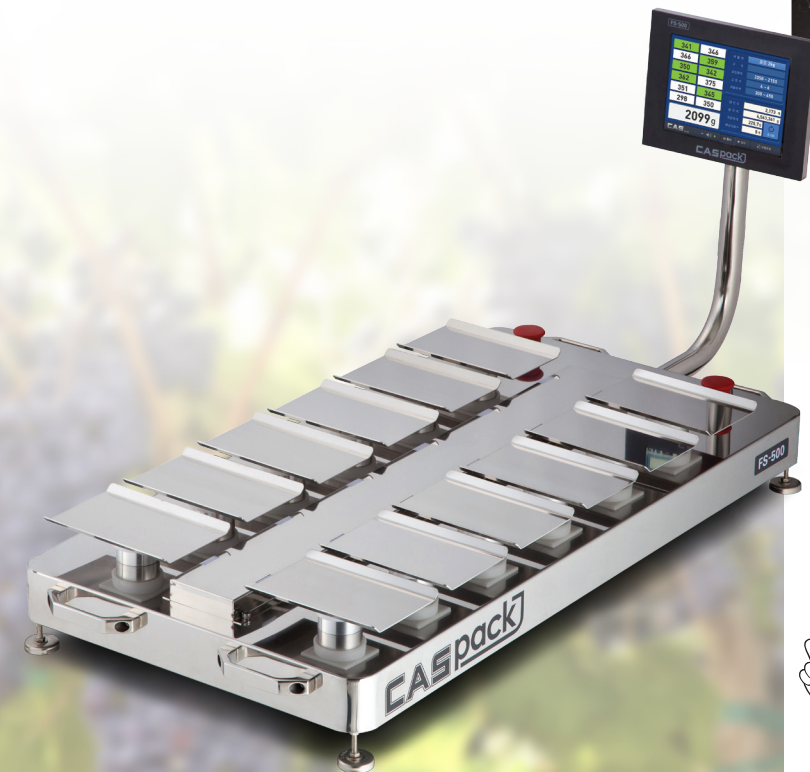

Scan with your smartphone to find more products

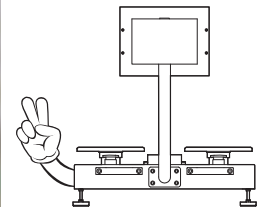

Alarm

Detachable Tray

Mix Weighing System

FS-500

Automatic Combination Weigher

Features

Alarm

- LED lamp for status light and sound
- Normal Combination : Green light / 'Ding-dong'
- Error : Red light / 'Ding'
- Upper / Lower weight : Yellow / No sound



Detachable tray

- Designed compactly and detachable tray for easy cleaning



Mix weighing system

- Mixed combination for other materials each other (Option)
Ex.) Mixed combination for Yellow and Red based on yellow paprika

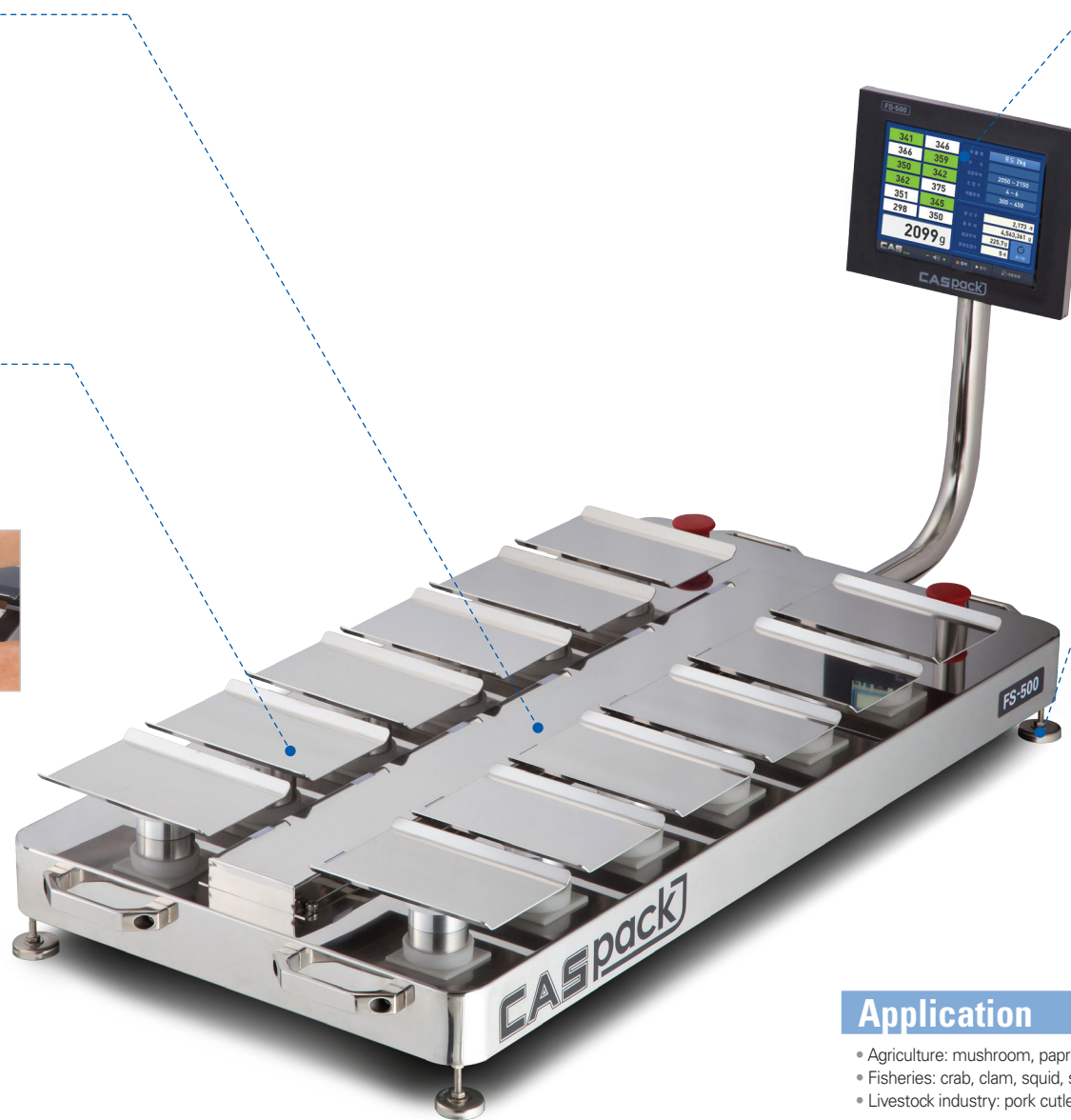

Touch display

- Applied to 8" large touch screen and register 64ea goods for easy control



Set '2kg' for the unit of one box

Pack the only green light products

Total weight of only green light products is 2kg

Table type

- Easy to move and install

Data management

- SD card for accumulation and weight data back up (Option)

Application

- Agriculture: mushroom, paprika, sweet potato, cucumber, grape etc.
- Fisheries: crab, clam, squid, shrimp, dried fish etc.
- Livestock industry: pork outlet, sliced ham etc.